

# glaspaper

critical writings on architecture and space

Against the noisy clamour for perpetual war against terror and the immediate bombing of Iraq it is easy to forget that the Labour government in the UK was elected on the basis of promises to invest heavily in education. By raising standards in schools and universities their plan was to put the UK at the forefront of the new 'knowledge led economy'. **04**

This issue of glaspaper focuses on 'Education and Learning', examining the consequences of such policies and asking questions about the way in which these terms have been framed to suit those in positions of power. Highly publicised increases in spending on schools and the privatisation of buildings and services through the adoption of Public Finance Initiative (see glaspaper 03) has seen massive school building programmes rolled out across the country. The city of Glasgow has recently seen the completion of a PFI renovation and maintenance contract worth £1.2 billion, involving 29 secondary schools – 12 being completely rebuilt. We examine the environmental implications for the students and staff who shall work in these buildings for the next 25 years.

That an economy should be 'knowledge' led is rather like saying that a train should have an engine and travel on rails. Who controls what we mean by knowledge and benefits from its commercial application? Why is it that despite large increases in the proportion of young people attending university the gap between rich and poor shows no sign of narrowing? >>

&gt;&gt;

The changing landscape of higher education stands as testament to the government's ambition to link the skills learned in the education system directly to jobs. The commodification of learning sees its logical conclusion in the school or university as supermarket, where students behave like consumers, purchasing the necessary knowledge to secure them a place in the service led economy. Along with such changes come 'consumer rights' which sees degrees exchanged or returned in much the same manner as a washing machine or a pair of trousers.

In an attempt to address this creeping shift away from the principles of universal education for the advancement of the human condition, *glaspaper* shall use this and future issues to share and disseminate knowledge and information which can be used to resist the excesses of market logic and develop ways of learning based on solidarity, liberation and joy.

Along with a useful guide for those living with sufferers of Alzheimer's Disease, we have included a special pullout supplement called 'Information Exchange'. It is very much work in progress and we would welcome suggestions for its expansion. It shall form the basis of a user-friendly guide that can be pinned up in the workplace or community centre.

*glaspaper* 04 marks our first anniversary and we would like to thank all of you who have supported us through subscriptions and distribution. Our readership covers many parts of Europe, North America and Australia. GLAS members were even able to distribute copies in Tokyo and Copacabana Beach, Rio over the past twelve months. If you haven't yet subscribed and would like to see the continued publication of *glaspaper* please use the coupon below. This issue has been generously funded by The Innovation Fund part of The Scottish Policy on Architecture National Programme.

We are planning to produce a special double issue (*glaspaper* 06/07) on 'Capital Buildings' to coincide with the opening of the new Scottish Parliament building in Spring 2003. As usual if you have any comments or contributions we are happy to receive them.

By the time you read this paper, a mindless attack on the people of Iraq may be underway. As architects we see it absolutely as our duty to speak out against such cretinous violence. Such protestations must be made in publications like *glaspaper* and all others for that matter. We hope you feel likewise and might be moved to use our back cover to express your feelings.

*GLAS is a co-operative of architects, teachers, writers and urban activists*

*GLAS is committed to fighting all manifestations of socio-spatial inequality, exploitation and deprivation*

*GLAS produces multi-media critical works and design ideas that promote a radical social and political rethinking of how we make and experience buildings and cities*

*GLAS is engaged in a critique of the capitalist production and use of the built environment*

*GLAS is committed to the dissemination of it's ideas to as wide an audience as possible, exploring a broad range of communication techniques*

*GLAS aims to offer free advice and assistance to individuals and social groups engaged in struggles to transform their environment*

*GLAS is organised around the political principles of temporary existence and of collective self management and ownership of assets and ideas*

#### **G.L.A.S. are**

Rosalie Adams, Allan Atlee, Judith Barber, Jason Bell, Gary Boyd, Jonathan Charley, Alistair Clements, Tony Dunworth, Florian Kossak, Carole Latham, Alan Pert, Tatjana Schneider, Adrian Stewart.

This issue has been funded by

**The Lighthouse**

#### **SUBSCRIPTIONS**

G.L.A.S. relies on the support of friends and sympathetic organisations around the world as we wish to continue distributing the majority of copies to community groups for free.

**glaspaper** is produced quarterly and will be sent via 1st class post to you.

**glaspaper** is produced by Glasgow Letters on Architecture + Space Limited. All material in **glaspaper** may be reproduced in full with the prior consent of G.L.A.S. Ltd. editorial address: Glasgow Letters on Architecture and Space Ltd. 31A Errol Gardens Glasgow G5 0RA phone: 0044 141 4296891 e-mail: info@glas-collective.com www.glas-collective.com

**ISSN 1476-3206**

printed by Scottish County Press Ltd.

- I want to subscribe
- £10/ EUR 17** Reduced Rate
- £20/ EUR 35** Standard
- £50/ EUR 80** Institutions (3 copies)
- £50/100+/ EUR 80/160+** Friends

Name \_\_\_\_\_

Address \_\_\_\_\_

City / Postcode \_\_\_\_\_

e-mail \_\_\_\_\_

Please make cheques payable to Glasgow Letters on Architecture and Space Ltd.

I am a member of a Community Group and would like G.L.A.S. to contact me.

Community Group \_\_\_\_\_

Name \_\_\_\_\_

Address \_\_\_\_\_

City / Postcode \_\_\_\_\_

e-mail \_\_\_\_\_



**GLAS** gets lost in King's Cross, uncovering hidden networks of support and surprise page 6 / 7

**GLAS** offers practical design advice to people living with Alzheimer's Disease page 8 / 9

**GLAS** still believes that PFI/PPP is a daft idea page 10 / 11

**GLAS** believes all citizens have a right of access to any information or education that may assist them in transforming their environment page 12 / 13, 14 / 15, 16 / 17

**GLAS** promotes representative community-led organisations that enable grassroots democracy page 12 / 13, 14 / 15, 16 / 17

**GLAS** examines the role education plays in the programmes of some of Europe's Architecture Centres page 18 / 19

**GLAS** supports the struggle against Housing Stock Transfer as it moves to the site of the future Scottish Parliament page 24 / 25

**GLAS** checks out what bargains are on offer now that our universities resemble supermarkets page 26 / 27

## essay

## IS IT MORE IMPORTANT TO BE CORRECT OR RELEVANT?

## A meditation on forgetting

**"For this invention of yours will produce forgetfulness in the minds of those who learn it, by causing them to neglect their memory, inasmuch as, from their confidence in writing, they will recollect by the external aid of foreign symbols, and not by the internal use of their own faculties. Your discovery, therefore, is a medicine not for memory, but for recollection, - for recalling to, not for keeping in mind.**

**"You are providing for your disciples a show of wisdom without the reality. For, acquiring by your means much information unaided by instruction, they will appear to possess much knowledge, while, in fact, they will, for the most part, know nothing at all; and, moreover, be disagreeable people to deal with, as having become wise in their own conceit, instead of truly wise."**

Plato (c. 427–347 BC), recounting the response of the Egyptian God Thamus to Theuth's invention of letters

A recent survey published in one of the glossy news magazines – I forget which one exactly – revealed that something like 60% of British adults could not recall the events which led directly to the United States' war on Iraq in 1990. Furthermore some 40% couldn't say for sure which side had won. Without wanting to lend credence to Jean Baudrillard's daft assertion that 'The Gulf War Did Not Happen' these opinion poll results should make everyone concerned during the current rush to war with the same country. Unarmed with a direct recollection of the conflict a decade ago, a clear majority of the British population will rely instead on the half truths circulated by the popular press (*glaspaper* included) and the authoritative lies peddled by our elected governments and their officers of the state; the CIA, MI6, Mossad, etc.

Odd perhaps that such collective amnesia should go unnoticed and unchecked. Odd because our society places such value on the powers of recollection. We see this everywhere in our popular culture. It isn't an accident that the television show 'University Challenge' is based largely on retrieving facts and references (a charmingly old world pub quiz for the chattering classes?). Or that the annual 'Brain of Britain' award was handed out to individuals who could recall every entry in Pear's Encyclopedia rather than the men and women responsible for cloning sheep, inventing the World Wide Web or devising the 'Post-It Note'. Memory is the virtue and forgetfulness the sin.

Memories define what we are. We are what we remember. A person without memory is person lost in a world of codes and signs. This character appears frequently in fiction and cinema, illustrating the consequences of attempting to navigate the modern city without the charts of memory. Losing the powers of recall in old age is seen as an irritation in its mild form and devastating when extreme. Our race, our gender, our social class, our nationality. All are groups we feel we belong to or identify with through collective memories. Nations can only be nations because of what their citizens have in common. What they remember - the words to the national anthem, oral histories, custom and ceremony. Equally nations are bound by what they have collectively forgotten. The Tate Modern Art Gallery stands as a new symbol of Britishness, yet who could derive great pride and togetherness from the memory of its origins in the sugar and slave trading of the family who gave it its name and wealth?

Memories and their authentication give individuals a sense of who they are. They place value on the self amidst the morass of others. The common obsession with family trees and genealogies is an attempt to document and

authenticate particular memories. placing the interesting and valuable ones in a loftier position than their mundane counterparts. On this subject American theorist Lewis Hyde illustrates the absurdities of his own family's genealogical amnesia. His family proudly trace their ancestry to William Hyde, an early pioneer. Lewis Hyde calculates that in the twelve generations separating him from his famous forbear there are some 2048 other individuals who go without mention – no doubt rustlers, rapists and murderers amongst them. This example is in its own way an attempt to 'destroy the fantasy of origins' (the lifeblood of all nations) - something Michael Foucault mapped out in his 'Archaeology of Knowledge' (or was it another text?).

#### Education and Memory

Our education system rewards recall. Anyone who has undertaken high school exams will have their own memories of mundane repetitions. This writer read and recalled only one novel, one play and one poem in order to pass national school exams and proceed to higher education. Participation in regulated exams that rely on memory probably prevents many young people from reading widely and intuitively. Pushing children through study programmes in English Literature may well make them able to read better but may simultaneously prevent them from becoming better readers!

In order to pass their professional exams and enter the exclusive club of their peers, architecture students must study, remember and recall regulations and contractual clauses to demonstrate future competence. The majority of building regulations and contract jargon is drafted in response to accident, mishap and negligence. It is worth considering that permission to practice architecture (as is the case in many professions) is granted through the acknowledgement of, and compliance with complex legal codes that have been shaped by the worst conduct and incompetence of past generations. Following this logic, drama students should scrutinise daytime soap opera and car mechanics forced to dismantle and reassemble Yugos. Here the art of memory can be linked directly to the forced timidity and mediocrity of future practice.

#### Strategies of Forgetting

If the art of memory is at times burden shouldn't we be exploring strategies of forgetting? Seen not as a disability, rather as a positive and even deliberate act, could forgetting allow us to occupy spaces hitherto deemed out of bounds? Preparing to leave the house for the day, how often have you forgotten where you have left your keys or wallet? Similarly

in the minutes spent searching frantically how often have you stumbled across another unrelated item or subconscious thought that you then decided to take with you for the day to enrich the experience? Trivial for sure, but a clue perhaps to tactics which might be applicable elsewhere. Forgetting suggests a pause. It often goes hand in hand with 'losing track of time'. Decelerating the velocity of a particular moment. If the colonisation of time and acceleration of natural rhythms was one of the prerequisites to the capitalist system of accumulation then might the voluntary daydreams of forgetfulness be one small tactic of resistance?

If our identity is defined by what we remember, then we can only possibly hope to change our identity by forgetting. During the Great Migration to America in the Nineteenth Century Europeans were handed leaflets at Ellis Island urging them to 'FORGET YOUR PAST, YOUR TRADITIONS IN ORDER THAT YOU CAN BECOME AMERICANS'. The dangers are clear. Taken literally such advice results in our current predicament where many citizens of the world's most powerful nation neither know where Iraq is nor what its people have suffered but are at the same time sure that it must be destroyed. However the sentiments are interesting. Could it be possible to redefine yourself as American – freer, no longer dragging around the European corpse of memory? All attempts by nations to move on from troubled pasts have relied upon processes of forgetting and commemoration. Unlike in South Africa, Germany or Chile, the apparent unwillingness to escape the tyrannies of memory is dragging Northern Ireland back into the worst excesses of its past troubles.

The prospect of forgetting everything is as unattractive as that of remembering everything. Both become Groundhog Days filled in the first instance with the constant repetition of experience, the latter by the constant recollection of past actions. (Consider that to truly remember every action in its minutiae would occupy the same amount of time as the act itself. It is believed that dreaming during unconsciousness is the mechanism by which we filter our brain of unnecessary memory and detail). If we accept then that forgetting can be an essential and attractive cognitive act we must address if and how it can be deployed to our advantage.

There are numerous examples of creative individuals who have attempted to deploy tactics of forgetting to create particular types of work. Musician John Cage believed it was important to 'forget the past in order to be more in the present'. Such practice throws up the possibility of existing in a state in which everything is a discovery, every sound constantly new. This form of creative

meditation, like all other forms of meditation is about being attentive to the moment, not the past.

**Learning and Forgetting**

Such deliberate strategies force us to reconsider our attitudes to education and learning. How do our schools and universities come to terms with the idea of appropriate forgetting? Must teachers reassess their role in the context of such a process? Can and should forgetfulness be encouraged and rewarded? Rethinking the learning process to include tactical forgetting forces us to simultaneously question what part memory will play in our development. What if we reconsider the role of the teacher as someone who doesn't teach you things but helps you remember things you already knew? Accepting that all human beings are born loving and with an intuitive sense of reliance upon and interdependence with the pack, then surely it is to these valuable roots that remembrance should lead us. Why is it that we forget the art of play, discovery and experimentation during the course of our education yet are conditioned to remember our place within the hierarchies of society?

Could these strategies of appropriate forgetting be applied to the general education of architects? Like doctors, lawyers and engineers, architects are taught to rely heavily on precedent, creative, technological and legal. But need this be the case? For a doctor it is important to remember why the administering of 1000 milligrams of morphine might not be a good idea. Lawyer justify their existence by remembering the actions of other lawyers memories of past actions. The stresses on a beam have a significant bearing – if you will pardon the pun. Architects on the other hand can only differentiate themselves from builders by generating ideas about buildings. A set of drawings, certainly in the hands of a student isn't going to cost others their lives or large sums of money. Would a newly graduated architecture student pose a risk to society had he or she not studied the work of Le Corbusier, Mies van der Rohe or Frank Lloyd Wright? This is not to argue for the abolition of historical study from architecture degree courses. But a danger? Many might argue that to unburden students of the positivist canons of Twentieth Century architecture would be a step forward but this is not the point.

Architectural education in the United Kingdom is becoming highly regulated, prescriptive and increasingly homogeneous. Universities are compelled to place ever-greater emphasis on 'essential components' within their degree programmes. This places great restraints upon the student and the teacher, pushing the spirit of invention and the respect for ideas further and further down the pecking order of priorities. Competence can be demonstrated

by the recollection of convention. The fostering of invention requires the rediscovery of play and justice. This requires considerable forgetfulness. Forgetting that the speculative nature of the development of the production of our built environment is nothing more than the recycling of despair and defeat. Forgetting that a drawing is not a building – just a drawing, an idea held captive in a moment in time. Forgetting that architecture is the process of designing buildings on demand and remembering that it can only be relevant if understood as a socially useful endeavour.

Cedric Price believes that the Royal Institute of British Architects (read all professional bodies) has 'forgotten its real reason for being, namely to improve the delight and usefulness that society draws from the products of its members.' (A circus? A Magic Circle? A Dream Factory?) He consequently argues that the RIBA should stop attempting to determine the nature and quality of schools of architecture, instead linking with those schools that match its intellectual aspirations at any one point in time. Wise words. If, as Price has also stated, architecture is too slow to solve problems and should concern itself with creating 'new appetites' then the student of architecture shouldn't concern him or herself with the ponderous conventions of the profession, which will most likely be redundant by the time it matters. Forget about it. Our institutions of learning – the universities, schools, talking shops and pubs should become places that generate free space through forgetting. Only remember what really matters. Whatever that might be.

Allan Atlee

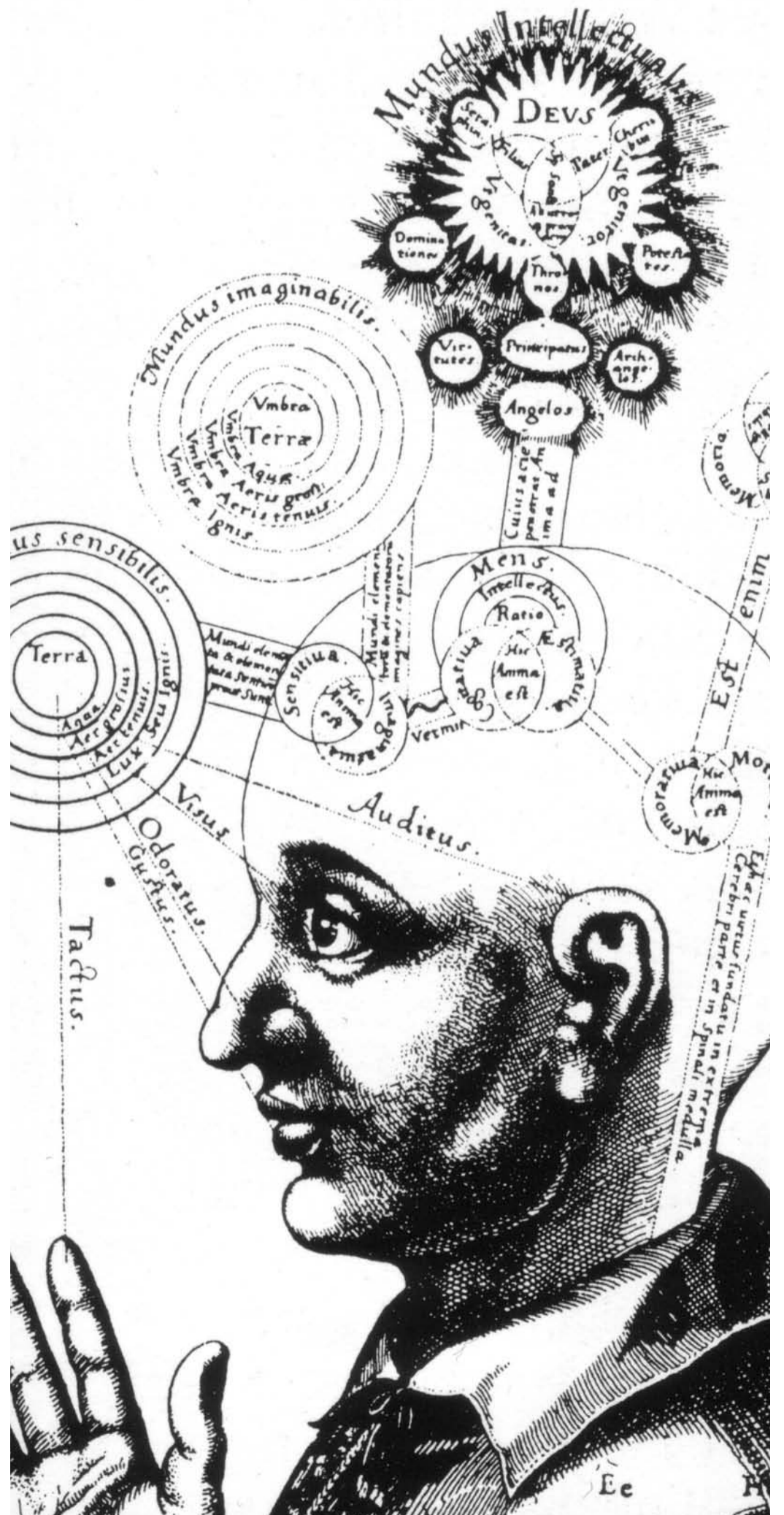

# LOST IN KING'S CROSS

The Kings Cross Area of north London is subject to a large scale development which will amongst other things see Channel Tunnel links integrating with the British rail network. As is typical in most developments a local community is overlooked as a source of decision making and knowledge. Familiar communication networks exist in the experiences of everyday people, but often have no part to play in the planning decisions made by financiers and politicians.

The Architecture Foundation invited G.L.A.S. to work for one day with a group from a local Bangladeshi community centre which would be the first their series Futuropa Participative Design Workshops with communities around King's Cross.

During that day GLAS sought to document the experiences and knowledge of a group of teenaged boys living close to the redevelopment area.

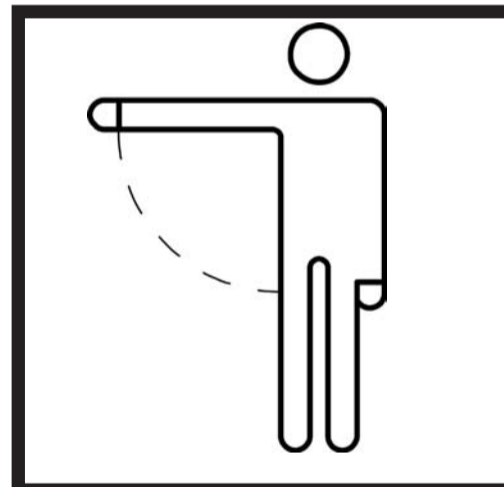
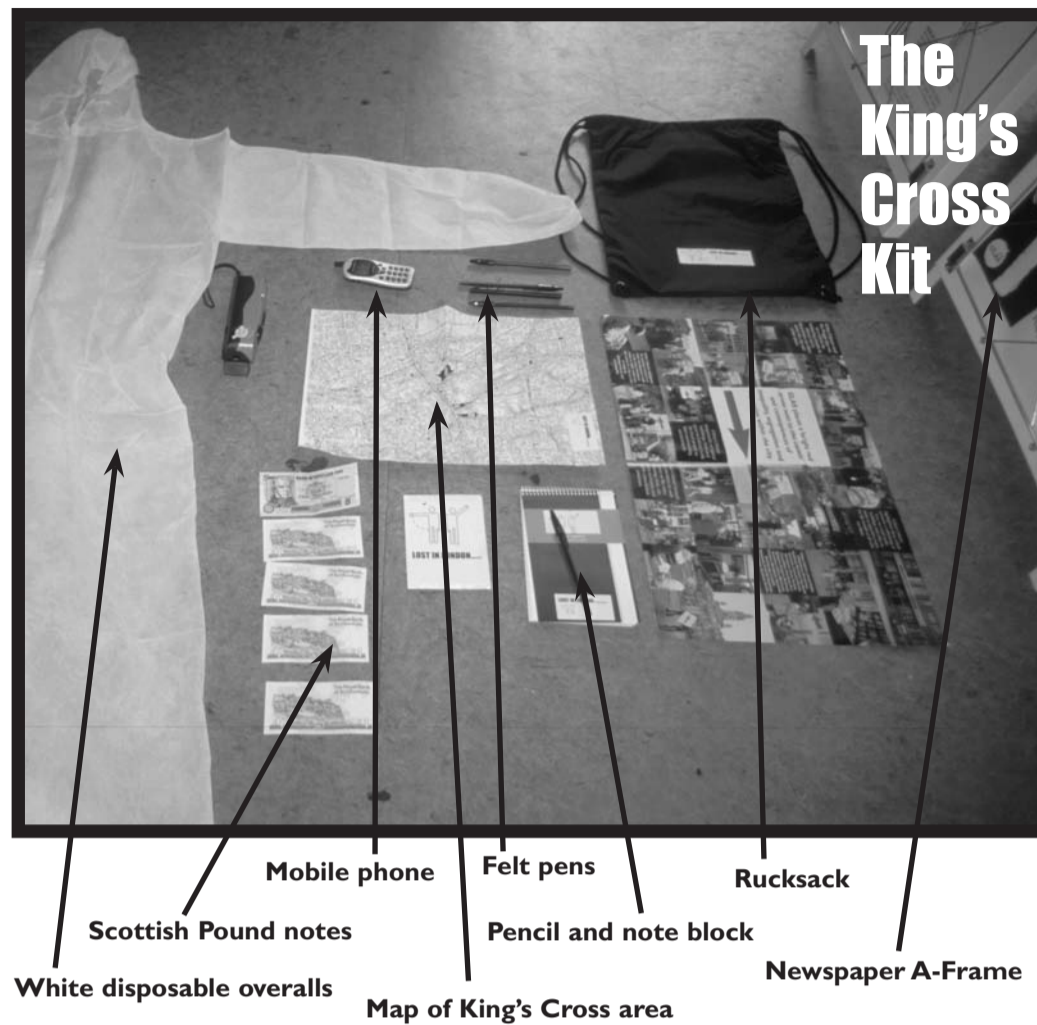

**11.13 Hrs**

"WE'VE GOT TO FIND A BARBERS HERE!"  
 "There are barbers..."  
 "We've got to ask someone!"  
 "EXCUSE ME LADY! Where are you from? Do you live around here?"  
 "Do you know where the barber is? BARBER! Haircut shop man you know..."  
 "Yeh down there... Caledonia Road."  
 "Second Left? OK, Cheers mate!"  
 "Lets go..."

A temporary network was established to seek-out, document and display useful visitor information through signs and physical interventions designed to greet those arriving at Kings Cross. By adopting familiar communication methods two teams with mobile phones responded to SMS messages relayed from Kings Cross Station, and their finds were in turn communicated to arriving train passengers in newspaper A-boards and human signposts.



**11.21 Hrs**

**SMS relayed to Kings Cross Station:**

**BARBER SHOP 205 KINGS CROSS ROAD MENS HAIRCUT FROM 6.50 FOR NORMAL CUT OLD PEOPLE 4.00 KIDS UNDER 12 5.00**



### The Base at King's Cross

11.23 Hrs  
SIGN IS DISPLAYED IN A-BOARD AT KINGS CROSS STATION



**NANDOS CHICKEN RESTAURANT FOR LUNCH – Take the 30 Bus towards Islington.**  
**HELPFUL STAFF AT INTERNET CAFE High Street off Euston Road 5 Min walk**  
**A GREEN SPACE IN THE CITY Purchase Street Open Space Coopers Lane**

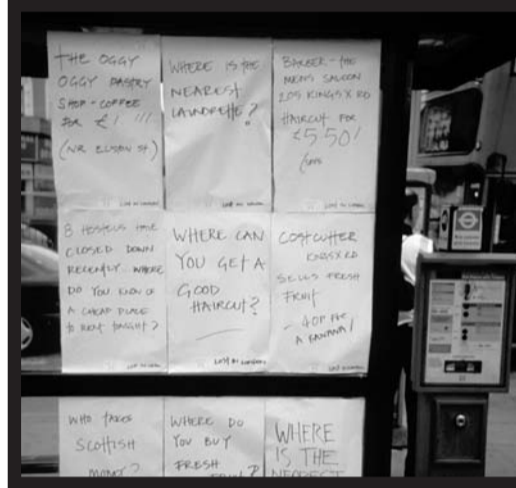

Bus shelter acts as info box

A-Frame with local information

Continuous gathering of information

Map of King's Cross area

A human sign post



Thanks to Fox, Imran, Khaled, Raj and Tashkin from the Surma Centre.

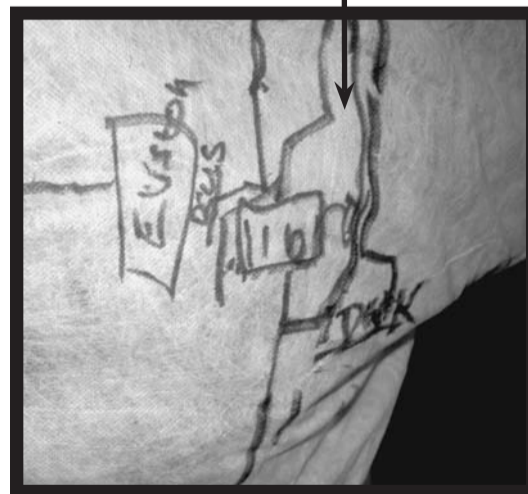

all images by G.L.A.S.



**For People from Scotland King's Cross has historically been an important place of arrival in London.**

**As result of economic, social or personal problems Scots would often leave their friends and families and travel south in search of employment and opportunity. Without a familiar support network and arriving unprepared without money or local knowledge, many Scots have found themselves caught in a poverty trap in King's Cross.**

# 11 STEPS TO AN ALZHEIMER'S FRIENDLY HOME

The elderly population in Britain is growing annually with improvements in healthcare and lifestyle, as a result of this the number of people with Alzheimers is higher than ever. Current research shows that some very simple alterations to the home environment can provide a significant improvement to the quality of life of someone with Alzheimers.

The Glasgow firm Chris Stewart Architects have indicated eleven such suggestions for home improvements.

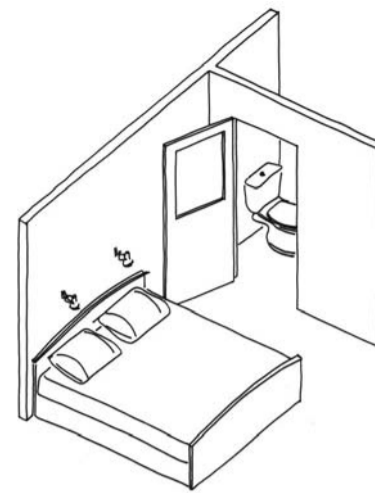

## 1 BATHROOM TO BEDROOM PROXIMITY

If possible, the bed should be positioned to allow a clear view of the toilet - this can help avoid confusion during the night and resulting continence problems.

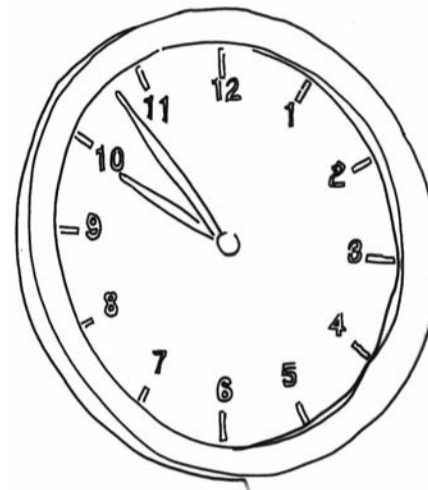

## 4 LARGE CLOCK

A large clear clock well positioned can help orientate people within the home.

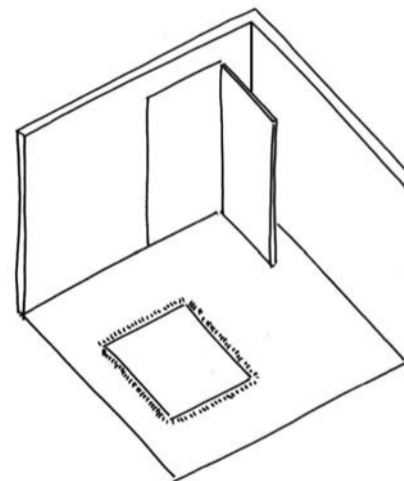

## 7 SURFACE FINISHES

Small items should not be left around on the floor and rugs should be anchored. Avoid shiny wall and floor finishes as these can be interpreted as change in level or wetness.

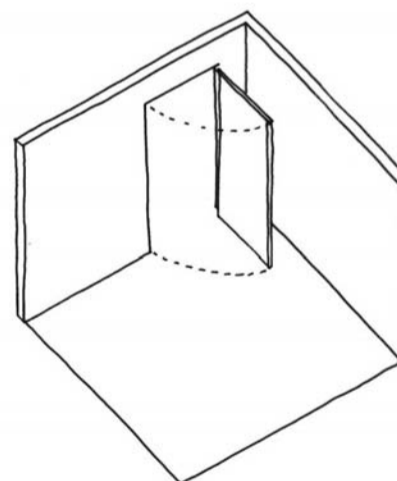

## 10 DOOR SWING

Where possible the door into a room should swing away from the main space to maximise the view and orientation before entering.

The following texts and information have been taken from the web site of Alzheimer Scotland - Action on Dementia. For more information please visit [www.alzscot.org](http://www.alzscot.org)

### What is dementia?

Dementia is the progressive loss of the powers of the brain. The most common cause is Alzheimer's disease. Other kinds of dementia are vascular dementias (including multi infarct dementia), alcohol-related dementias, Lewy body dementia and Pick's disease. What all these diseases have in common is that they damage and kill brain cells, so that the brain cannot work as well as it should. In Scotland, over 58,000 people have dementia. It is most common in older people but can affect people in their 40s or 50s or even younger.

### What are the symptoms?

Every person with dementia is different. How their illness affects them depends on which areas of their brain are most damaged. One of the most common symptoms of dementia is memory loss. It is important to remember that everyone forgets things sometimes. Most people's memory gets worse as they get older. But when someone has dementia, they may forget the names of family members, not just of strangers. They may burn pans because they have forgotten them or forget whether they have eaten lunch. They may repeat the same question again and again and not know they are doing it.

People with dementia may lose their sense of time, losing track of which day it is or of the time of day. They may lose track of where they are, and get lost even in a familiar place. They may fail to recognise people they know well.

People with dementia may often be confused. Their ability to think, to reason and to calculate can all be damaged. They may make odd decisions and find it hard to solve problems. Handling money may become difficult as they find it harder to work out



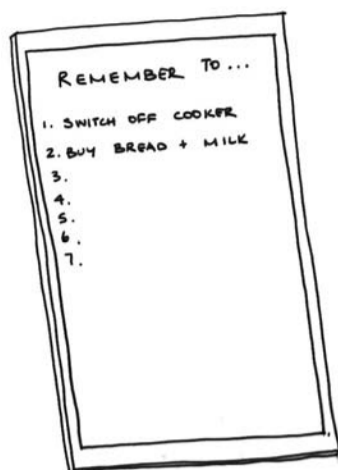

## 2 KITCHEN BLACKBOARD

A blackboard in the kitchen can act as a 'Remember to do' list.



## 3 EMERGENCY HANDBOOK

A clear and concise handbook with important contact numbers, including family members, friends, helpers and the police can prevent panic in an unfamiliar circumstance - a photograph of the person beside each contact will also reduce confusion.

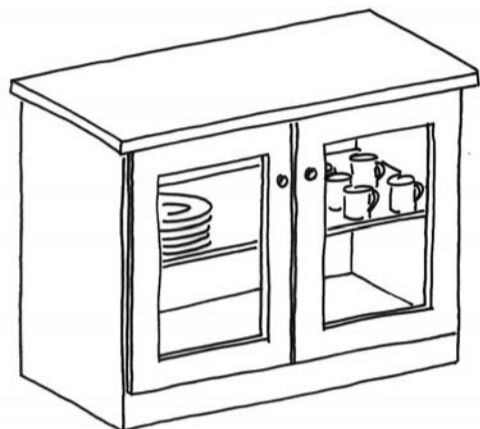

## 5 CLEAR FRONTED STORAGE UNITS

Clear fronted storage can assist with orientation and carrying out general tasks around the house.

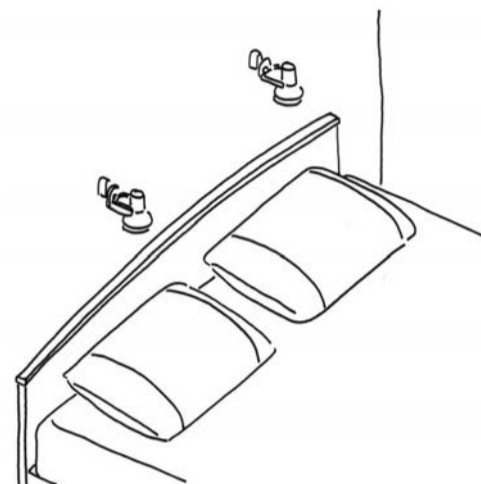

## 6 GOOD READING LIGHTS

Make the best possible use of natural light where possible and install good quality reading lights which do not produce glare or strong shadows.

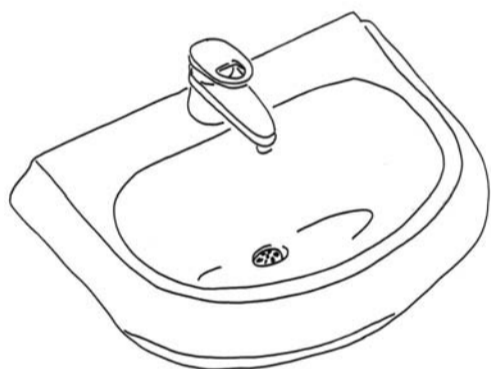

## 8 HOT WATER TEMPERATURE

If there is a problem or fear of scalding it is possible to install a temperature restrictor or reduce the thermostat temperature at the boiler.

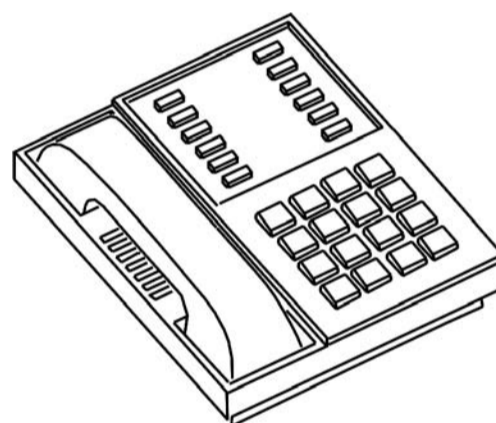

## 9 TELEPHONE DIALLING

Telephone dialling is often confusing, using preset dial buttons with a photograph of the face of the person to be called beside will help reduce confusion.

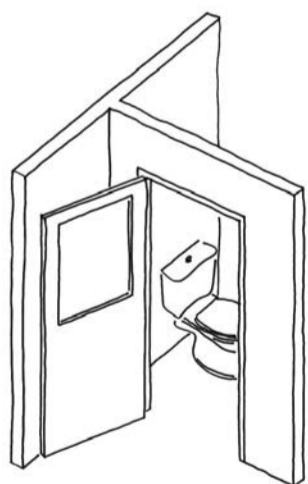

## 11 BATHROOM DOOR GLAZING

The addition of a coloured translucent glazing panel into bathroom doors often assists with orientation, especially during the night.

Adrian Stewart

their change or lose their sense of the value of money.

Dementia can also cause personality changes. Someone who was active and energetic may become listless, someone pleasant and well-mannered may become rude and aggressive. These changes can be particularly distressing to relatives and friends as they lose the person they knew.

Gradually, over a period of years, most functions of the brain will be affected. Eventually, people with dementia will probably need help with even simple daily activities, such as dressing, eating or going to the toilet.

### What can I do?

If someone you know has dementia, you will have to come to terms with the fact that he or she will not get better. Talk to someone about how you feel and what you can do. You can call the 24 hour Dementia Helpline free on 0808 808 3000 at any time.

- Share your feelings with other members of the family or friends.
- Tell the doctor about any changes.
- Find out what services are available. Try to get as much help as you can.
- Find out about benefits and claim them.
- Talk to other people with dementia or families and carers who are facing similar problems.
- Try to make life as full and enjoyable as possible. Both people with dementia and carers should try to get out and about and keep in contact with friends.
- Don't just put up with new difficulties. Ask for information, help and advice to cope with problems.

# IT'S PFI ... AND BUST

## Glasgow's Project 2002

**“The ambitions of this government are bold. In education they are nothing less than a revolution in school standards. ... Nothing we do is more important than giving our children the schools they deserve.”**

*Tony Blair, British Prime Minister at the Head Teachers Conference, 20.10.1998*

**“PROJECT 2002: Raising Standards through world class facilities.”**

*'Project 2002' published under [www.glasgow.gov.uk/html/council/dept/schools/main/htm](http://www.glasgow.gov.uk/html/council/dept/schools/main/htm)*

**“It is the Executive's aim to act as an exemplar client in its procurement of buildings, whether through Private Finance Initiative or traditional means, and we recognise that good building design is a key to obtaining value for money.”**

*Mike Watson, Scottish Secretary for Sport, Media & Culture, published in 'PFI Scotland' Issue 14, April 2002*

**“We believe that the quality of our architecture and of our urban and rural places, is a reflection of our cultural aspirations and is vital to the perception of Scotland as a place of imagination, creativity and innovation.”**

*Extract from " A Policy on Architecture for Scotland" by the Scottish Executive*

**“A quality learning environment raises pupil morale and in turn generates respect. All 29 secondary schools will be in a top quality condition by August 2002.”**

*'Project 2002' published under [www.glasgow.gov.uk/html/council/dept/schools/main/htm](http://www.glasgow.gov.uk/html/council/dept/schools/main/htm)*

**“Whether you are looking for tradition or innovation, boldness or understatement, an architect can lift your project out of the ordinary. Anyone can alter a building. It takes a professional to do it with flair, imagination and style.”**

*Extract from RIAS brochure 'Why use a Chartered Architect'*

**“A chartered architect is obliged to uphold the reputation of the architectural profession and fellow professionals.”**

*Extract from "RIAS Clients' Advisory Guide to working with an Architect"*

**“In a public / private partnership project, the risk attached to any solution must be with the contractors. The accommodation provided must be fit for the purpose and reflect in full the Council's output specification. If there are flaws in the solution (e.g. a school design is not fit for the purpose) then the contractor will experience severe financial penalties and will have to rectify the problem.”**

*'Project 2002' published under [www.glasgow.gov.uk/html/council/dept/schools/main/htm](http://www.glasgow.gov.uk/html/council/dept/schools/main/htm)*

In November 1999 Glasgow City Council selected the consortium 3Ed as the preferred bidder in a PFI process to provide the city with all secondary educational facilities for the next 25 years. The programme, which is worth £1.2 bn and was named 'Project 2002', is supposed to be the biggest Public Private Partnership in the UK education sector. The package includes not only the complete transfer of the school building stock to 3Ed with the obligation to bring them to a modern standard, either through renovation or construction of new buildings, but also the future maintenance, security, janitation, cleaning, and heating of these buildings. The council will lease the school buildings back for a period of 25 years after which they would go back into the hands of the council. 3 Ed, - a term that derived from Tony Blair's mantra 'Education, Education, Education' -, consists of the companies Miller, Amey, Morse, Mitel and Hewlett Packard. The selected architects for all 29 schools were the Edinburgh based firm Percy Johnson-Marshall & Partner. From finalising the 1:200 drawings and, with it, the overall costs of the project in December 1999 to the start of construction in June 2000 took only six months. The refurbishment and construction of almost all 29 schools was finished in less than two years to match the council's target line, August 2002.

The results are as disappointing as the ambitions for this project were bold. To build 'schools for the 21st century', to create 'stimulating and supportive learning environments'. Project 2002 was to 'raise standards though world class facilities'. What the council, and more depressingly generations of future school children got are buildings that are indistinguishable from any bland office building in an out of town industrial estate. The qualities of interior and exterior spaces are unimaginative and nowhere near those of contemporary schools elsewhere in Europe. The way in which the schools are constructed leaves no opportunity for future change to meet new space and teaching requirements. Why Glasgow had to rush into this operation, why they believed it is now or never without taking the time to do one or several schools at a time to learn from mistakes that inevitably occur in such a process remains a mystery. If the Council claims financial reasons then one has to attest them a terrible short-sightedness that left them with a building stock that wont be worth a penny after those 25 years when they fall back to the city. If it wouldn't be such a tragic waste of money and a waste of opportunity for real improvement of the education environment one would just have to lough. But time is up for just laughing about it.

Florian Kossak

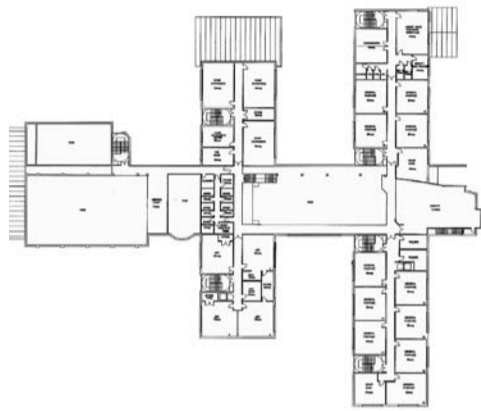

All Saints Secondary School,  
Ryehill Road, Glasgow



Lochend Community High School,  
Cairnbrook Road, Glasgow

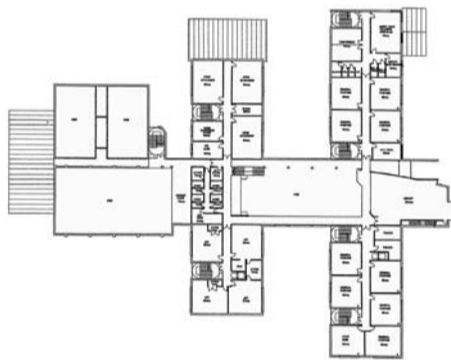

Smithycroft Secondary School,  
Smithycroft Road, Glasgow



Springburn Academy  
Mansel Street, Glasgow



## THE



The Glasgow Rent Strikes occurred over 80 years ago. However, the story of people united against injustice, willing to take direct action and then witnessing the impact, is no less relevant today.

This piece has been taken from interviews held with Jim Wallace, Cathie Mailer, Tommy Stewart, Mary Barbour and Jessie Scott. These Interviews were originally recorded by The Govan Reminiscence Group, and are a first-hand account of how individuals were involved in the rent strikes.

The Govan Reminiscence group meet at the Hills Trust Community Learning Academy, to collect photographs, stories, interviews from local characters about important events, buildings and people in Govan's history. This has already formed an extensive database for the local and wider community.

#### The causes of the Glasgow Rent Strikes

JW: In 1914 over 13,000 houses were lying empty, but very quickly after the start of the war, people moved to Glasgow for work. In January 1915 Glasgow Houseowners Association decided to increase rents by 6%. As wages had been frozen during the war, many people were unable to meet the costs of the rent increases. In June 1915 the president of South Govan Women's Housing Association, Mary Barbour and Andrew McBride, Independent Labour Party Councillor led the call to refuse to pay the rent increases. McBride had tried to get the local Government involved, but all refused to intervene. Direct Action was the only route left.

#### How the women organised themselves

JW: Mary Barbour, with others, organised the women into a committee of two volunteer representatives should volunteer from each close to meet every Monday at a local Church Hall. Posters and leaflets were issued for distribution, you could see the posters in just about every window in Govan: "Not paying rent increases and not being removed." Meetings were also held in back-courts and closes.

#### Tactics used during the Rent Strikes

JW: When the Sheriffs arrived, children would run to other streets, pass notes from their mothers to other women "Tell them we're out", and then everyone would start ringing bells, blowing whistles, and everyone was pouring from the streets. Women would block the streets where the eviction was taking place, so no Sheriff Officer could get near it. During one eviction attempt, where the

women threw flour and peasemeal 'bombs', chased the factor for his life, and said "well he didn't get his money, but he got his breakfast!"

CM: When the evictions were happening, the Sheriff Officers could only put people out between 10 and 4 o'clock. So the women held up the closes every day, letting no-one past. We always sang 'The Red Flag' when the Bailiffs came round!

#### The long term benefits of the Rent Strikes

JW: The Women's Association didn't stop meeting after the strikes, and a large number of people involved in the Rent Strikes become political after it. Mary Barbour was elected the first woman Labour Councillor.

TS: The Govan Womens Housing Association continued to meet until recently, educating people that we still need houses for rent and at a rate people can afford.

Carole Latham

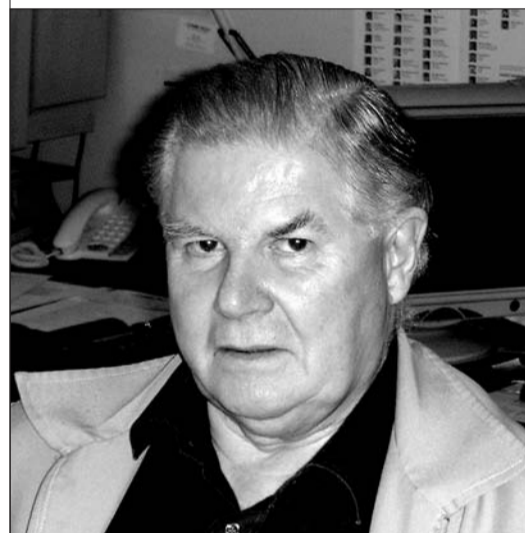

George McKie is convener of the Edinburgh Tenants Federation and a representative of the Gracemount Tenants Association, launched in October 1990. The Federation is an umbrella organisation of local associations that represents tenants citywide. It promotes tenants' rights and works for improved housing conditions for all tenants of rented accommodation, in particular those at risk of discrimination or social exclusion.

#### G.L.A.S. How did Edinburgh Tenants' Federation first get formed?

GM: It started from two separate groups – the Network of Edinburgh Tenants for low rise properties and Flats Fight Back Organisation which represented the tenants in high rise blocks, and then another group, Sighthill Tenants Association. We thought 'This is daft, let's bring it all together. So, it took some time to actually do that, and some were resistant. After a couple of years of the Federation, we got Council funding to get an office and employ staff.

#### G.L.A.S. Do the different associations meet together or do you go out to individual Associations?

GM: Both, staff play a big part in helping train residents, to encourage them to develop local groups and how to take up issues. We hold quarterly members meetings, and these are the policy making bodies of the Federation, the members meetings, representatives of the as many local groups as want to participate.

#### G.L.A.S. What type of issues are raised?

GM: We have working groups on a whole range of issues that people become involved in, and not necessarily housing related. Since we all live in communities there are more issues in communities than houses! We don't really have the resources to do all the things we'd like to do.

#### G.L.A.S. What kind of resources do you need?

GM: More staff... It's too much to expect volunteer tenants to do these things.

#### G.L.A.S. Are there any other organisations that you find are helpful to you?

GM: For training and information, we have found we've used the Tenants' Information Service a great deal. It's a Tenant run organisation with a committee elected by tenants from across Scotland through a postal ballot once a year.

#### G.L.A.S. How do tenants mobilise themselves to form associations? Is it an easy process?

GM: No, it's not an easy process and generally there's still areas in Edinburgh that have no tenants' associations or residents' associations of any kind. It usually takes a local issue that people are angry about to bring them together and then the difficulty is getting them to widen from that one issue. So we are trying to get people to realise that there's a whole range of issues, concerned with housing and the community in general, that people can be involved in. And I like to think that it's a way of expanded democracy. The more involvement there is the better it is. It's a real democracy that's not got a political slant to it. I mean in a non party-political sense – everything's political!

#### G.L.A.S. I imagine for people to get involved, the timing is critical?

GM: Yes, well that's the whole aim of trying to develop tenant participation and making it work in practice is to be involved right from the start. It does get people interested and it does expand their knowledge. As they go on they want to know more and more so that they are better informed. It's a great process; it's a wonderful process.

#### G.L.A.S. How do you start that off?

GM: You have got to get people interested right at the start to feel that however little they know, they can still have an impact. As the knowledge and confidence develops they realise 'we are the people who live in these houses, we are the ones who know about his community.' We know a damn sight more about it than the professionals do. We have got to tell them, otherwise they don't know. If they don't know they'll do the wrong thing.

#### G.L.A.S. The SERC's (South Edinburgh Resident's Council) – is that co-ordinated through the Federation?

GM: They are members of the Federation... We help set it up. It is an umbrella group for residents' and tenants' organisations in the South of Edinburgh... We concentrated our outreach worker in the South of Edinburgh for a couple of years. And then we got funding from the South of Edinburgh Partnership to help develop tenants' groups.

>>continued on page 17

The Information Exchange is intended as a database of information, contacts, and advice. Any group seeking to embark on a programme of action, applying for funding or dealing with building related issues, support from similar organisations can prove invaluable.

These interviews are the start of a process which aims to promote existing organisations who have already made things happen. G.L.A.S. believes that this part of the Information Exchange can also provide a critical examination of the ways in which our current legislative and economical systems work and how manipulate them to your collective advantage.

# INFORMATION

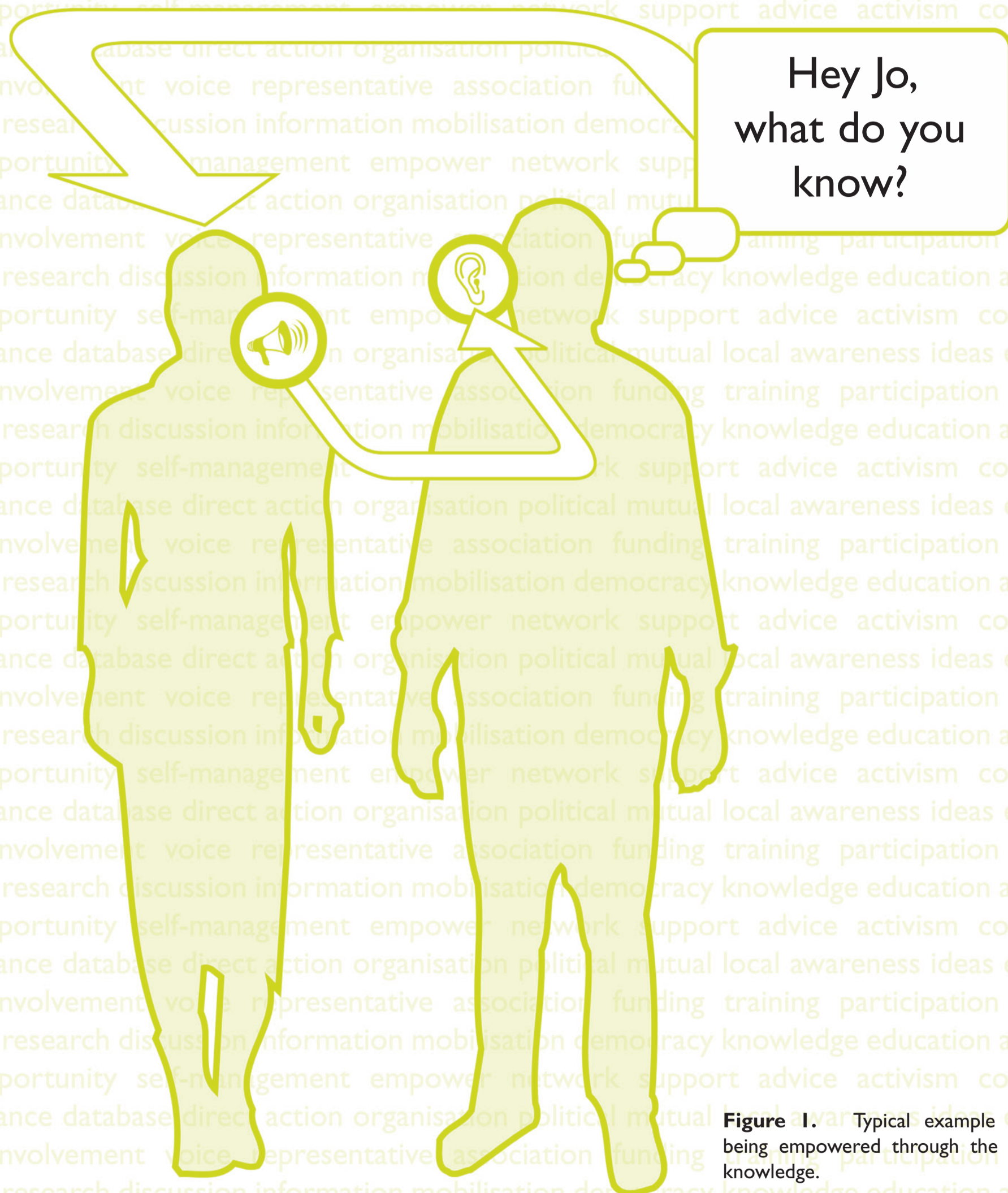

**Figure 1.** Typical example of people being empowered through the sharing of knowledge.

# EXCHANGE

**Are there any other groups or organisations out there that can offer support and advice?**

**RADICAL ROUTES**  
A network of social, housing and workers co-operatives that believe in equality and co-operation. Promote and organise participatory education through skills and knowledge sharing, distributing informative material and through workshops. Raise finance to allow control over resources, (property, technology and land) Contact: Cornerstone Research Centre, 16 Sholebrook Avenue, Chapeltown, Leeds; [www.radicalroutes.org.uk](http://www.radicalroutes.org.uk)

**TENANTS' FEDERATIONS**  
Umbrella organisations for local tenants' associations that represent tenants' views  
The Scottish Tenants Organisation campaigns vigorously on government finance, support maintenance and for good quality public sector housing  
Contact: Scottish Tenant Organisation, 304 Ellon Park, Glenrothes, Fife Tel. 01592 570207  
[www.scottishtenants.pwp.blueyonder.co.uk](http://www.scottishtenants.pwp.blueyonder.co.uk)

**COMMUNITY PLANNING**  
Community Planning is a strategic process employed by local authorities which aims to begin working in partnership with local communities. The Community Planning Task Force promotes the active involvement of communities in decisions on local services.  
Contact: Scottish Executive Tel. 0131 244 0420  
[www.communityplanning.org.uk](http://www.communityplanning.org.uk)

**We have received information about a proposed building in our area -how do we find out more?**

**PLANNING**  
Most building work and changes of use require planning permission before work can go ahead. There is a weekly list of all planning applications registered at the Council and you can inspect these at your local Planning Office. All Councils prepare land-use for their areas called Local Plans. You can review these at Libraries. For more info contact: Scottish Executive Planning Help-line Tel. 08457 741741

**PLANNING OBJECTIONS**  
When building work is planned within close proximity to your home you will be sent a Neighbour Notification Form describing the proposals. Details of applications are also advertised in the Local Press. You can view all plans at your Local Planning Office. You have the right to object to proposals. This must be done in writing to your local Planning Department, signed and dated within 21 days of advertisement in the Press.

**DO YOU KNOW SOME MORE INFORMATION? DO YOU HAVE ANY COMMENTS?**  
**PLEASE FILL IN FORM OPPOSITE AND SEND IT TO G.L.A.S.**



**SOCIAL INCLUSION PARTNERSHIPS (SIP's)**  
SIP's consist of the local authority and other public agencies, voluntary sector, health boards and local enterprise companies. SIP's aim to get the best out of existing community initiatives and support additional activity such as improving access to employment, education, childcare, health matters. For local SIPs contact: Communities Scotland Tel. 0131 313 0044

**COMMUNITIES SCOTLAND**  
Executive agency of the Scottish Executive set up to take forward Ministers' priorities in relation to Community Regeneration. Formerly known as Scottish Homes.  
Contact: Communities Scotland, 91 Haymarket Terrace, Edinburgh, EH12 5HE  
Tel. 0131 313 0044  
[www.communitiesscotland.gov.uk](http://www.communitiesscotland.gov.uk)

**CITIZENS' ADVICE BUREAU**  
The Citizens' Advice Bureau is a professional national agency that offers free, confidential impartial and independent advice. It helps solve problems including debt, consumer issues, benefits, housing, legal matters, employment and immigration. Advisors can help fill out forms, write letters and negotiate with creditors and represent clients in court or tribunal. Contact: Citizens Advice Scotland. Tel. 0131 667 0156

**We have some ideas and thoughts about some potential projects in our area - how do we test if they are feasible?**

**SCOTTISH COMMUNITY PROJECT FUND**  
Grants available through the RIAS to community led organisations that wish to employ an architect to prepare a feasibility study for a building or environmental improvement project. Awards half the cost of the feasibility study to a maximum of £1500 incl. VAT.  
Contact RIAS Tel. 0131 229 7545

**G.L.A.S.**  
Glasgow Letters on Architecture and Space  
G.L.A.S. aims to work with groups to develop their proposals from as early a stage as possible through, campaign propaganda, exhibitions, feasibility studies and workshops. G.L.A.S. is a non-profit-making organisation. Contact: 31A Errol Gardens, Glasgow. Tel. 0141 429 6891  
[www.glas-collective.com](http://www.glas-collective.com)

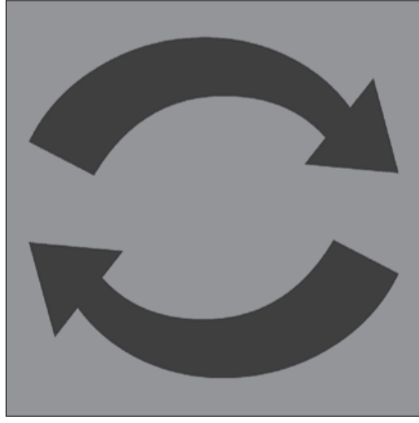

**Are there any public sources of funding to support our community activity?**

**GRANTS AND FUNDING GOVERNMENT WEB SITE**  
Comprehensive governmental web site that outlines grants and funding resources at Local, National and European level.  
[www.fundraising.co.uk](http://www.fundraising.co.uk)

**RIAS**  
Royal Incorporation of Architects in Scotland  
RIAS is the professional institute for chartered architects in Scotland. It offers a range of services to all those interested in the built environment and the design process. The RIAS can suggest 3 or more architects suitable for your project. This service is free. Contact: RIAS Client Services 15 Rutland Square, Edinburgh Tel. 0131 229 7545  
[www.architecture.com](http://www.architecture.com)

**URBAN DESIGN ALLIANCE**  
Government-run scheme called 'Place Check' through the Urban Design Alliance (UDA) where you identify positive and negative qualities of your area. The UDA gives guidance on how to involve local people, politicians and professionals to show what improvements are needed and how to work with others to achieve that. National Place Check Day - 22nd Sept. 2002. Contact: UDA, ICE Engineering Dept., 1 Great George Street, London, SW1P 3AA. [www.placecheck.com](http://www.placecheck.com)

**LOCAL AND NATIONAL PRESS**

Getting the local press in particular to support your campaign can be very effective.

For basic information on setting up a press release check out [www.press-release-writing.com](http://www.press-release-writing.com).

This web site advises on content basics and gives 10 essential tips.

**LOCAL COUNCILLORS**

Councillors meet regularly to decide how your Council's services will be provided. Your Councillor is there to represent your views.

You can contact your councillor to express your views. Most Councillors hold regular meetings called Surgeries. Contact your Local Council Office for information on where to contact your area Councillor.

**Our local community centre has been threatened with closure. We want to let people know about our campaign**

**CO-OPERATIVES**

Co-ops are jointly owned and controlled associations based on the values of self-help, self-responsibility, equality and solidarity.

UK Co-op Council promotes the interest and support of co-ops generally  
Tel. 0161 289 5290 or [www.co-op.co.uk](http://www.co-op.co.uk)  
For advice on housing co-operatives contact the Housing Advice Service of your local area housing office.

**SMALL BUSINESS GATEWAY**

The Small Business Gateway is a service provided by Scottish Enterprise Network. A range of integrated services is provided offering assistance for business information, business start-up and growth. Most services are free of charge.

Contact Helpline on 0845 609 6611  
[www.sbgateway.com](http://www.sbgateway.com)

**As a newly formed organisation we need advice on setting up a business - who can help us?**

**LEGAL AID**

Legal Aid allows you, if you would not otherwise be able to afford it, to have the help of a solicitor for legal problems. To receive legal aid you must first consult a solicitor who will help you complete an application.

The Scottish Legal Aid Board is responsible for managing Legal Aid in Scotland.  
Contact: 44 Drumsheugh Gardens, Edinburgh, EH3 7SW

**Sch NEWS**

Open Media Collective who publish a weekly newsletter highlighting direct action events and anti-capitalist issues. The website is an extensive source of information, news and links including a DIY Guide to direct action for Protest, Legal Advice, Setting up a Co-op, Subvertising, Company Research, Media Activism, Community Action and Campaigning. SchNEWS, PO Box 2600, Brighton, BN2 2DX 01273 685913, [schnews@brighton.co.uk](mailto:schnews@brighton.co.uk), [www.schnews.org.uk](http://www.schnews.org.uk)

**We are frustrated and want to take direct action - what do we need to consider?**

**GOVERNMENT INFORMATION**

[www.ukonline.gov.uk](http://www.ukonline.gov.uk)

Useful website with links to all local and central government websites for legislation, information, and government departments.

For Scottish Executive information  
Tel. 0131 5568400  
[www.scotland.gov.uk](http://www.scotland.gov.uk)

**AWARDS FOR ALL and THE COMMUNITY FUND**

National Lottery

Awards grants to charities, voluntary and community groups across the UK. Community Fund: For projects up to £60,000  
Awards for All Programme: Grants of £500-£5000 for small groups  
Tel. 0141 223 8600  
[www.community-fund.org.uk](http://www.community-fund.org.uk)

**We have heard about lottery funding for community based projects - how do we apply for this and who could help**

**INNOVATION FUND**

Arranged through the Scottish Executive and coordinated by the Lighthouse Centre for Scottish Architecture.

Awards grants for built environment related projects within communities at a local level, i.e. for changing a public space, renting occasional premises for contact with the public. Grants of £1000-£5000 available.  
Contact: The Lighthouse  
Tel. 0141 221 6362  
[www.thelighthouse.co.uk](http://www.thelighthouse.co.uk)

**COMMUNITY COUNCILS**

Community Councils can be set up to represent the views of local communities and act to ensure their well being. They consult with local people and present those views to the Council and other public bodies.

For further information contact Association of Scottish Community Councils, 21 Grosvner Street, Edinburgh.  
[www.ascc.org.uk](http://www.ascc.org.uk)

**Do you know any helpful group or websites? Then write to GLAS at 31A Errol Gardens, Glasgow**

**INFORMATION EXCHANGE EXCHANGE INFORMATION**

*fold here*

**GLAS is working to develop and expand the Information Exchange to encompass new networks and links. The information presented here is just a beginning.**

**The aim is to create a constantly developing database of information that any group or individual can access through the web or through contact with GLAS.**

**The dissemination of information will be at its most powerful if there is a continual exchange of information between GLAS and others. Please contact GLAS if you have any comments, contacts or helpful information to pass to others.**

[www.glas-collective.com](http://www.glas-collective.com)

*fold here*

**COMMENTS / INFO**

\_\_\_\_\_

\_\_\_\_\_

\_\_\_\_\_

\_\_\_\_\_

\_\_\_\_\_

\_\_\_\_\_

\_\_\_\_\_

\_\_\_\_\_

Name: \_\_\_\_\_

Address: \_\_\_\_\_

\_\_\_\_\_



management empower network support advice activism co-operati  
 ect action organisation political mutual local awareness ideas experier  
 e representative association funding training participation resourc  
 on information mobilisation democracy knowledge education alternati  
 nagement empower network support advice activism co-operati  
 ect action organisation political mutual local awareness ideas experier  
 e representative association funding training participation resourc  
 on information mobilisation democracy knowledge education alternati  
 nagement empower network support advice activism co-operati  
 ect action organisation political mutual local awareness ideas experier  
 e representative association funding training participation resourc  
 on information mobilisation democracy knowledge education alternati  
 nagement empower network support advice activism co-operati  
 ect action organisation political mutual local awareness ideas experier  
 e representative association funding training participation resourc  
 on information mobilisation democracy knowledge education alternati  
 nagement empower network support advice activism co-operati  
 ect action organisation political mutual local awareness ideas experier  
 e representative association funding training participation resourc  
 on information mobilisation democracy knowledge education alternati  
 nagement empower network support advice activism co-operati  
 ect action organisation political mutual local awareness ideas experier  
 e representative association funding training participation resourc  
 on information mobilisation democracy knowledge education alternati  
 nagement empower network support advice activism co-operati  
 ect action organisation political mutual local awareness ideas experier  
 e representative association funding training participation resourc  
 on information mobilisation democracy knowledge education alternati

fold here

**GLAS.  
 GLASGOW LETTERS ON ARCHITECTURE AND SPACE  
 31A ERROL GARDENS  
 GLASGOW  
 G5 0RA  
 SCOTLAND**

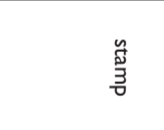

stamp

fold here





>>from page 12

**G.L.A.S. Were there no tenants' groups there before that?**

GM: No. The work was getting such that our outreach work was concentrating on the South and neglecting the rest of the city. So SERC, funded by South of Edinburgh Partnership, employed somebody dedicated to work in South Edinburgh and we could continue to work in the rest of the city.

**G.L.A.S. Has that been successful?**

GM: Yes in so far as the project that we managed proved that one member of staff was not enough to actually do the development work that was required there. We put together an extra bit to South of Edinburgh Partnership to set up the Community Development Initiative. After a lot of harassment, arguing, knocking on doors and twisting of arms, we succeeded in getting funding from the Partnership which included the Empowering Communities money from the Scottish Executive which goes to SIP's. Which according to the guidelines under the Scottish Executive should be under community control. We made sure it was under community control.

**G.L.A.S. What kind of things do they get involved in?**

GM: They have premises in the South of Edinburgh, linking up with other community organisations to create a real community infrastructure. Building a set-up that will continue long after the Partnership has long gone.

**G.L.A.S. Because the relationships will be established?**

GM: We think we are building something new and worthwhile. It's entirely in community control. It's got teething problems just now because it's only been in existence a few months but we'll get there, we've got big ideas! We'll make sure things happen. We have to get across the message 'you can be there and be involved. You can have a say, you can have an influence.' And at the end of the day if you've got a good idea it'll be adopted. It's convincing people that they can make a difference. And they can.

**G.L.A.S. So, what is the Planning Participation project about?**

GM: ...develop participation at an early stage. In line with the new requirement on landlord's to develop a participation strategy because of the Housing Scotland Act. Through the Scottish Tenant's Association we fought bloody hard to get tenant participation in that Act, which it wasn't originally intended to be. What really bugs me is its short-termism. You get funding for 2, 3 years – but what happens after that? There's no qualms about setting up some educational systems which are statutory bodies but the idea of having community development that is not statutory but community led, and has to be short-term? That's not good enough. The need is always there.

**G.L.A.S. The issues don't go away. That would be your criticism of these funds?**

GM: Even the Empowering Communities money from the Scottish Executive fed through SIPs is specifically to help with the development of Community Directors in SIPs and other local representatives. But that's

creating a little local elite, of well-trained people who will continue because there's nobody trained up to replace them. You've got to widen it and bring as many people on board as possible. Let's have competition for these places. Lets' make people feel 'I'd like to have a go at that'. So you have the confidence to stand down knowing that someone with competence is taking your place, whether you agree with them or not is beside the point.

**G.L.A.S. That's when it gets political.. rather to be seen to do something than actually doing it.**

GM: People say, 'community education is there to do that'. Community Education doesn't do anything like that. It's got to be community controlled. You've got to have a capable, educated, confident community, to be in control. It takes time to develop that.

Judith Barber.

Pat Eccles is a member of the New Town,



Broughton and Pilrig Community Council in Edinburgh. The Community Council aims to consult with local people and present those views to the Council or other public bodies. Pat has been particularly active in securing funding for local landscape projects.

**G.L.A.S. Have you been involved with the Community Council for a long time?**

PE: I've been retired for seven years and I didn't really want to get involved in that side of things again. But I found myself getting more and more frustrated and upset about the way Edinburgh's Planning is working, particularly the way in which the landscape is neglected. Someone said to me, 'Why don't you apply for a Millennium Award? ...about...lost tree covering...' So I did, I got an award and I got money. When it came to writing up the project I didn't want to produce a report. I thought, 'Who's going to read that?' I have friends who are artists and we held an art exhibition. We sold quite a lot of work and I kept the commission as a small pot of money to promote our project. It was a wonderful experience. I then had exhibition panels made about my project. So instead of a written report, you could go and look on the wall and see where the trees were lost. It was interactive as well. We had questionnaires. Part of this project was realising we should go ahead with this as a hands on project. People started to ring me up and say 'Do you know such-and-such a tree is being cut down. What can you do about it?' So I thought 'How can we get other people involved in the community?' and the best way seemed to be through the Community Council.

**G.L.A.S. How do people find out about the Council?**

PE: The Council tends to be made up of people who are already in street associations. There are further associations and interest groups, so that they are not completely unrepresentative. Managed to get a group of people to set up an Environment Group. We managed to get money, with much difficulty, to fund a Landscape Architect to do a study. The grant for doing the study is from the Landfill Tax, through Edinburgh Environmental Partnership. It is a nightmare.

**G.L.A.S. Do you mean that it was a complicated process? Are they particularly unhelpful or is receiving the funding a problem?**

PE: We are at a period where there is a culture that assumes that it is better to be positive with people, than negative. It's no good telling people that yes you can get the grant and it will be over in two weeks if that's not the case.

**G.L.A.S. Does the Community Council go along to the Local Development Committee meetings?**

PE: You don't really need to do that because the LDC haven't had these grants for a long time this is the second year, any organisations can apply for these grants once a year for a value of up to £5000. They haven't had many applications so it wasn't a problem other than meeting certain bureaucratic rules. So that all took some time – but we've got the hang of it now!

**G.L.A.S. Are there any problems you see with the Community Council, for example, could it be more open and encourage more people getting involved?**

PE: Yes, I think it gets stuck on a few key issues, which I am not saying are not important, it's a bit of a talking exercise and it puts some people off. I do think it could be more active and I'm sure it will move to that in time. One of the main jobs is to interpret local issues, ...and I think this is something that the council struggles with.

Judith Barber

Susan Brown is the director of Hawthorn



Housing Co-operative in Possil Park, Glasgow. Recognising the benefits and importance of combined community networks and resources, Susan recently helped set up a joined venture organisation with Glasgow Perthshire JFC. The joined venture aims to provide a vital community hub with housing offices, football pitches, and associated facilities.

**G.L.A.S. What were the reasons behind the forming of Hawthorn Housing Co-operative?**

SB: The Glasgow Perthshire Football Club approached Glasgow North Ltd. to try and sort out the clubs finances. A discussion was taken up with Hawthorn Housing Co-operative as it was felt that the two organisations could be mutually supportive and decided to consider a joint venture, accommodating the Co-operative and a state of the art sports facility.

**G.L.A.S. How did you structure your group, arrange contact and organise events?**

SB: The group started with the two organisations, other groups with an interest or specialist knowledge joined the two groups at the core. Although this has been helpful in some respects it has also caused problems. The formality and the size of the group led to the Perthshire withdrawing from it. Negotiations are still on going to resolve all this.

**G.L.A.S. Where did you access information to help the campaign, and did anyone provide assistance?**

SB: Support from Glasgow North who suggested the Lighthouse and they in turn suggested using G.L.A.S. to carry out the initial study. The Perthshire contacted various people in the football world who they felt might be useful. The Firhill Complex provided information. A representative from the Scottish Office also offered helpful suggestions and support.

**G.L.A.S. How did this assist your cause?**

SB: I know much more about the sports bodies involved and everyone knows a lot more about where funding comes from, how difficult it is to get. There is more awareness of the politics involved. Promotional events provided experience for everyone. The support, help and information was invaluable.

**G.L.A.S. Do you have any advice for others thinking about undertaking a similar joint venture?**

SB: Be careful you don't overwhelm often fragile local groups. Ensure groups resolve internal issues and do not let them flow over into joint organisations. Have a clear vision, by all means amend and alter it but don't be drawn away from it. Have one person or group leading. Otherwise joint ventures tend to drift and are no one's priority. If it is not the world you operate in try and find out as much as possible about the politics, funding etc. before you begin.

**G.L.A.S. What part does access to information and education play in Hawthorn Housing Co-operative?**

SB: Information is the lifeblood of a housing organisation, it has to know what is going on in its area to manage it effectively.

**G.L.A.S. How do you see this being strengthened?**

SB: The Co-operative is good at sourcing help. It probably isn't always good at looking at the learning opportunities contained in some of it.

Carole Latham

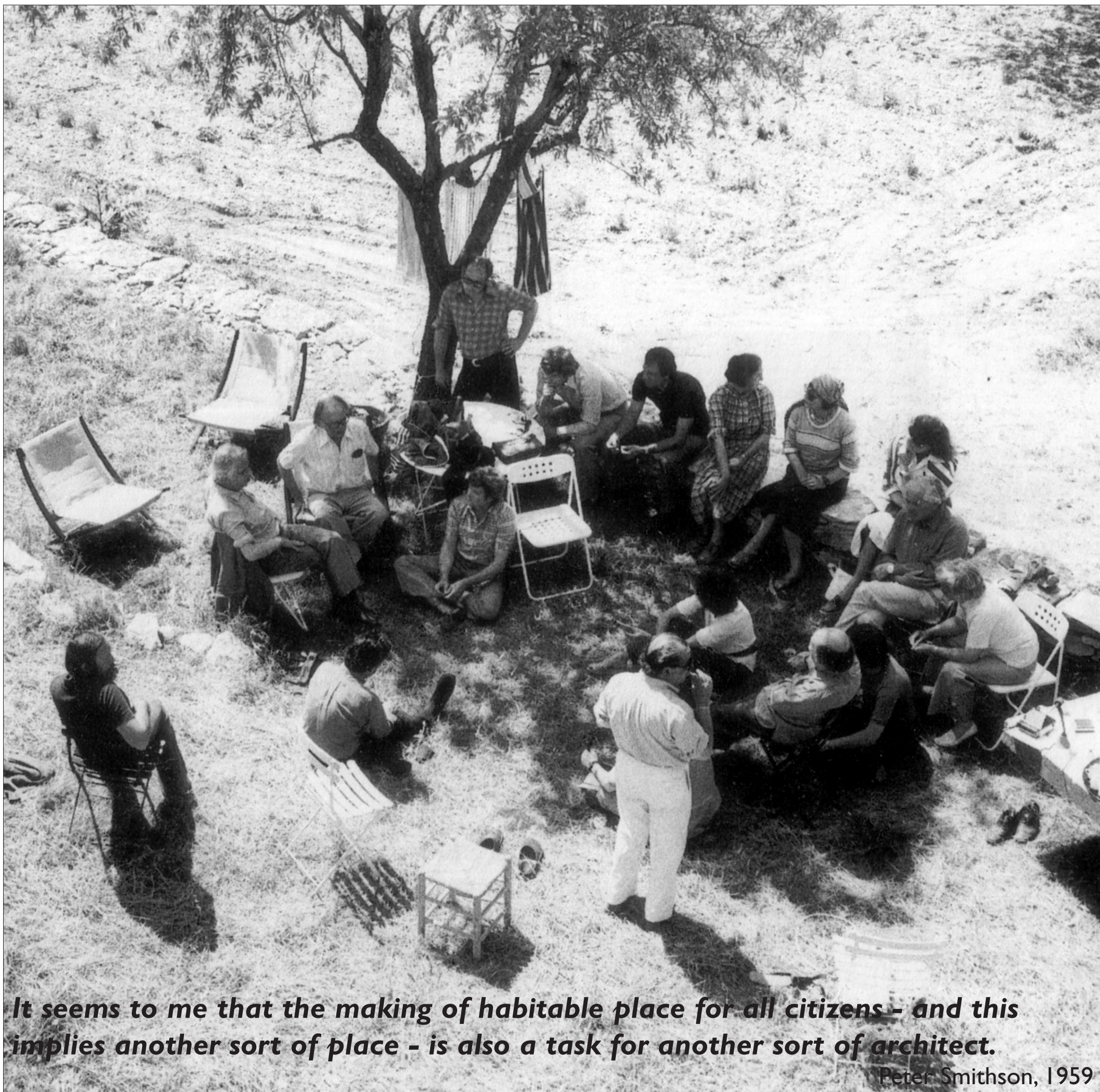

***It seems to me that the making of habitable place for all citizens - and this implies another sort of place - is also a task for another sort of architect.***

Peter Smithson, 1959

# THE VALUE OF ARCHITECTURE CENTRES

On the 18th and 19th June 2002 the Architecture Foundation in London organised the conference "The Value of Architecture Centres". The conference took place in the lecture theatre of the British Museum and was attended by a few hundred representatives from architecture centres, public and private bodies, and governmental organisations from Britain and around the world. The aim of the conference was to "communicate a new unified vision for British architecture centres through the exchange of ideas on programmes and policies."

'The Value of Architecture Centres', - the title of the conference came as a statement, not as a question. Maybe one should be always slightly suspicious of putting value to something. When we are talking about a general, a public value of an institution, of a service or something as incomprehensible as architecture we are in an even greater muddle. It might all lead to 'Value for money', the helpless mantra that has been attached under New Labour onto all public investments and even politics as a whole. In the end this could have lead us to a conference title 'How much value does an architecture centre need to justify its existence'.

As the title suggested, there was not one speaker at the conference who publicly questioned the value of architecture centres as such; most speakers would have talked themselves out of their job by doing so. So here they were, all convinced of the importance of what they were doing, but still talking about completely different things. The reason for that was, that, although it seems on first sight that the notion of an architecture centre is a pretty straightforward thing architecture centres can be all sorts of things. The range present at the conference varied from small private galleries to public museums, from national institutions to very locally operating organisations, from centres in purpose built buildings to centres that weren't centres at all but existed only virtually on the web.

One other apparent distinction between most British centres and those on the European continent was the way in which they approached the subject of architecture. Michael Snodin, curator at the Victoria & Albert Museum and director of the International Confederation of Architectural Museums, gave an important clue by saying that "Architecture in Britain is not sitting in the realm of culture". Francine Fort, director of *Arc en Rêve* in Bordeaux commented on this in an interview with G.L.A.S.: "What differentiates us is that we are more engaged into a cultural offering. On the one hand, in Britain, they work along the lines of 'apprenticeship', a vocabulary and a method to act and intervene within the process of participation, and on the other hand at places like *Arc en Rêve* much more an engagement

with a cultural offer to open up the insight for contemporary creations."

If that is the case, then the way in which those involved in the production of architecture talk about the subject here in Britain and how architecture is communicated in architecture centres respectively will be different from an approach in which a society regards architecture as something that has its place within the cultural realm. If architecture is not seen as a part of culture, something that is not following the logic of the authorship, as is the case with other creations of art, then it can be negotiated. It can also be approached rationally. Negotiation and the rationale open the door for participation and the provision of a set of tools to understand and in the end even create architecture. With only a few exceptions the British centres are all putting a very strong emphasis on this participatorial and educational aspect within their work. The idea of servicing a community as a whole rather than a limited, professional audience is central to the understanding that they have of their role as an institution.

A lot of this understanding has to do with the way or rather the conditions in which these institutions are funded. Like all other cultural institutions, information centres, or training facilities architecture centres do not generate enough money on their own to survive. They need funding either through national or local government, through professional bodies, corporate enterprises or in some cases individual donors. When we ask the questions, "What is an architecture centre?" and "Who is an architecture centre for?" we have inevitably to ask a third question that will determine the answers to the other two, "Who is financing the architecture centres and with what intentions?"

Tom Russell from Manchester City Council addressed the problems of funding architecture in his presentation. He said that "funding bodies liked clear and foreseeable settings or projects", and that "the diversity of programme and audience of architecture centres is making it difficult". He continued in saying that "Funding from public bodies must be regarded with caution because they are timely and it might restrict centres in their critical approach #to urban themes if funding bodies are not mature enough to accept the criticism."

Bart Lootsma, Dutch critic and architectural historian and one of the very few speakers at the conference not directly involved in an architecture centre was pointing in a similar direction when he argued that "The same government agencies that support architecture centres support the development of sprawl and the liberalisation of the building sector". After the conference G.L.A.S. had the chance to talk to Bart Lootsma and ask him

about the influence of architecture centres on the production of architecture, the role of participatory processes and education for architecture centres and the future of those institutions.

*G.L.A.S. The concept of architecture centres seems to be relatively new. An interesting question from your point of view as an historian would be whether these architecture centres were able to change the architecture in its physical outcome or whether they rather changed the perception of architecture.*

Bart Lootsma: You can find all kind of important incidents, in which the influence of architecture centres can be seen and in which architecture centres played a role. But of course the architecture centre is a new phenomenon. Compared to the situation in which, for instance, Modern Architecture was produced, - an architecture that was meant for a general audience, that was meant for the masses, in a much more homogeneous society -, to the situation in which we live today which is a society that is much more individualised and much more commercialised. That means that architectural production is much more depending on individual initiative and it seems that the architectural centres try to work with that and educate and train the individuals. On the other hand there is a contradiction in that because architecture is something that mediates between the private and the public. And as soon as it becomes so individualised you have to wonder what the public side of it is. Most governments in Europe are deregulating, privatising, withdrawing from the public sector and this implies that this public side of architecture becomes very unclear which makes the role of the architecture centres unclear.

*G.L.A.S. How would you describe the difference between architecture centres here in Britain and those on the continent, in countries like Holland, Austria or France? Our impression today was that the focus in Britain is more directed towards the process compared to countries like France, Germany, and Austria where it is much more directed towards the product.*

BL: Yes, I have the feeling that here in Britain there is a lot of focus on the process and the work with the community. That is in the Netherlands as well more and more the tendency. In France a lot of these institutions originate in art institutions. Their whole way of working is largely based on a collection, which is in this case an architectural collection. And from there on they work on all kind of educational projects that are both local and regional and sometimes very international and ambitious. What strikes me in Austria is that a lot of things go slower, that the privatisation and deregulation process is slower. And that means that they are very careful. In Austria architecture has also a high public esteem. That makes it very different. The institutions in Austria are very much driven by architects and there is a respect for architecture in Austria that I don't really know in other countries, Switzerland maybe.

*G.L.A.S. Do you see a future for architecture centres?*

BL: I absolutely see a future for them. Maybe not for all. I think the architecture centres that will mainly focus on process and on consultancy planning will disappear at a certain point. Those that manage to become

more autonomous and that are more like cultural institutions, will have a better chance to survive.

*G.L.A.S. Why do you think that is the case?*

BL: Well we have had this already. We went through that whole phase of process planning in the nineteen seventies. And the problem about it is that, when you are doing that to a certain point you don't propose anything anymore. Everything becomes a process, everything becomes unclear and it becomes very difficult to talk about quality, of cultural quality of a design. And I expect the same thing to happen with those institutions, both here in Great Britain - although I don't know them very well - but also certainly the ones in the Netherlands.

*G.L.A.S. Do you agree with the stance most British institutions took today at the conference that architecture centres should have a very strong educational aspect?*

BL: I think education is very important. But that is not something new. For the Modern Movement the constant working with the public was very important particularly in its early phase. In Vienna there would have been exhibitions in all kind of places in order to convince people to organise the city in a certain way or to built social housing. The same was happening in the Netherlands. Education is important, but what is really important is giving people an insight into how their city works, what kind of processes play a role there. In particular the relation between private and public, between private things and shared things, how that is organised and how that is maintained as well giving an insight into the economics behind architecture. But basically, when you talk about architecture I think in the long run you will also have to convey an idea about quality. And quality is choice. At a certain point someone has to propose something. So an architecture centre will also have to propose cultural exhibitions that are manifestations.

In Bart Lootsma's call for manifestations by the architecture centres lies probably a clue to the answer to the question: 'What is the value of an architecture centre'. If they simply retreat to a position which one of the speakers proclaimed by saying that "the real experts are the communities" then there might be no need for architects anymore and no justification for architecture centres alike. But then the profession would get away too easily. To refrain from making propositions, from taking a precisely defined stance on issues of the design and production of our environment is not just cowardly behaviour but patronising towards the very communities that one thinks should be included in a fair participatory process. Architecture centres must produce manifestations of high cultural and politically avant garde importance. If they don't give communities the chance to engage with these positions they are of no use and value because a useful participatory process can only be as good as the parts that contribute to it.

Florian Kossak

The Architecture Foundation is planning a publication of the conference to be published in spring 2003. For more information contact [www.architecturefoundation.org.uk](http://www.architecturefoundation.org.uk) or phone ++44 (0)20 7253 3334



Thomas Hirschhorn's

# BATAILLE MONUMENT



The Bataille Monument was a public art project by the Swiss artist Thomas Hirschhorn during the Documenta 11 in Kassel, Germany, from 8 June to 15 September 2002.

It consisted of eight interconnected, non-hierarchical elements: a sculpture, a Georges Bataille library, a Bataille exhibition, various workshops through the duration of the exhibition, a television studio with daily broadcasts on the Kassel public-access channel, a stand with food and drinks, a shuttle service from and to Documenta 11, and a website. The Bataille Monument was created with the help of various other artist and young residents of the Friedrich Wöhler housing estate in Kassel.





*“As an artist with a project in a public space I ask myself the following questions: Am I able to initiate encounters through my work? And, if so, am I able to create occasions through my work? The Bataille Monument is a precarious art project of limited duration in a public space, built and maintained by the young people and other residents in the neighbourhood. Through its location, its materials, and the duration of its exhibition the Bataille Monument seeks to raise questions and to create the space and time for discussion and ideas. The Bataille Monument comes from below; it does not seek to intimidate anyone; it is not indestructible; and it is not intended for eternity.”*

*“The Bataille Monument is dedicated to the French writer Georges Bataille (1897 - 1962). I take responsibility for this choice; it is a form of artistic engagement. I am a fan of Georges Bataille; he is at once a role model and a pretext. Bataille explored and deployed the principles of loss, of overexertion, of the gift, and of excess. ... Choosing Bataille means opening up a broad and complex force field between economy, politics, literature, art, erotica, and archaeology. ... Bataille has nothing to do with Kassel. The Bataille Monument is not a contextual work; rather, the monument could easily be shown in another neighbourhood, in another city, in another country, or on another continent.”*

*“I cannot produce the Bataille Monument alone. I am an artist; I have a project; I want to realise the project. I know that realising the Bataille Monument requires the help, support, and tolerance of the residents, including the younger ones. So I don't say: do it as I do, but rather: do it together with me. The site for Bataille Monument is the Nordstadt neighbourhood of Kassel, specifically, the Friedrich Wöhler housing estate. It is a site that assumes the reality that the construction and maintenance can be achieved, that friction and engagement are possible. ... The construction and maintenance are carried out by (among others) the young people of the Philippenhof Boxing Camp; everyone is paid for his or her work. I am not a social worker; I am not trying to revive this neighbourhood; for me, art is a tool to get to know the world. Art is a tool to make me confront reality; art is a tool to experience the time in which I am living.”*

These text passages are extracts from the official press text by Thomas Hirschhorn  
For further information visit [www.bataillemonument.de](http://www.bataillemonument.de)



# DOUBLE GLAZING, CENTRAL HEATING, MAGIC WANDS & CRYSTAL BALLS !

Neil, Vice-President of the Holyrood and Lochview Resident's Association talks to artist Lyn Löwenstein, about the 'ins and outs' of stock transfer.

*Lyn: I guess the thing for me to say to begin with is that I have no clear views on stock transfer. Until the recent news about Glasgow I honestly knew nothing about the whole thing, so now I'm trying to work things out. Andrew Wishart gave me this to read (The Dumbiedykes Stock Transfer Assessment).*

Neil: Oh dear!

*L: ...yes, some dry reading but a good introduction - what I didn't realise, for example, is that stock transfer is exactly what the council wants to see happen, that they don't really propose any alternatives.*

N: Yes, what it's all about is to bring in another landlord, who can borrow money without it being public borrowing and to get debts written off. They are basically being told what to do, and it is not necessarily coming from anyone within the council.

*L: So why is that? Why has the council not got the possibility to fund the regeneration of the estate in another way?*

N: Well, in a rational world they would, because they could in fact borrow more cheaply than a housing association could, because the council is the government and the government isn't a risk to lend money to. It's just the accounting rules that we have in this country mean that they don't distinguish between capital borrowing and day-to-day borrowing, and therefore it is simply an arbitrary rule to say the council cannot borrow money to do up this estate. That is the long and the short of it. Now as I say, it is not the council's responsibility, but the politicians as Labour party members cannot escape from it. It is the Labour government in London that sets these accountancy rules and it is the Labour government in Scotland that then implements them here on the ground. So basically, when council officers say we've got to do this, I accept that from them, but when politicians say that, I don't accept it from them. They are talking as if Maggie Thatcher was still running London and telling them what to do! It's all the same party. So whenever a Labour politician says, we've got no alternative, I don't accept that, unless they are publicly crossing the party line, which none of them will of course! So only the politicians can really answer the big question of why this is happening. I know that there is certainly no demand from the tenants or the owners here to change the landlord. If

people do vote to change the landlord, it will be accepting the blackmail or the bribery, however you see it, that this is the only way to get the flats done up to a modern standard. You know these are still 1960s kitchens and bathrooms and the electric storage heating really is no good and these flats do need quite some changes, just to make them reasonably habitable in wintertime.

*L: So why were they not maintained?*

N: Well, I've lived here only three years, but as I understand, it is many, many years since any real investment has been made, and I suppose five years ago before the parliament was to be put here etc. this was really a very run-down area where they would have had very little pressures on them apart from the local residents. The pressures that they are getting now again really aren't from us, it is because of who our new neighbours are that there is talk of doing these blocks up. I think they would still just not be an issue for the council, were it not for the parliament next door!

*L: So when the council say that they want to provide affordable, good quality housing in the city centre, can you accept that?*

N: Oh I do believe that that is what they would like if they could wave a magic wand and achieve it, sure. Almost everyone would accept that is their aspiration. But it's by no means certain that in 30 years time there will be more than a tiny amount of social housing in the centre of Edinburgh. So although it's an aspiration everyone would sign up to, it's still not a certainty.

*L: And in terms of the process, you are on the steering group. Who else is on the steering group?*

N: Well now, from our residents, nobody. In the past, Jan has been on and Sheila has been on, and Cheryl has been on, but they have, for different reasons, dropped out at different times. And whether our Association will be either inclined or able to give four people to the committee that will choose between the two bids, I really don't know.

*L: So what happens then?*

N: Well I would imagine the Council will find other ways to fill places that we don't.

*L: But it has to be residents?*

N: No, not necessarily, I suppose by law much of the consultation is possibly not required, other than the formal consultation when there is a ballot.

*L: So it's not a requirement to include*

*residents?*

N: Well, certainly it could go ahead if we don't participate. Whether there will be a ballot is by no means a certainty for various other reasons, but certainly if we decided not to participate it would go ahead without us, and it may be that is what we choose to do; to say we don't want it, so we are not going to talk about it anymore, we are just going to vote against it come any ballot.

*L: So, if there was a no vote, then it would be back to the drawing board?*

N: Yes, then it's crystal ball time, of course, no one can be quite sure what would happen, and the Council will say, before any ballot, what they will do for the estate if they win it, which will be virtually nothing. Of course that isn't an honest statement, because it's a strange bid where you have the Housing Association wanting to win the ballot, and the Council, which is the other side of the ballot, wanting to lose it! So if the Council are stuck with us then they would have to look again at what they could do here. My own feeling is that when the MPs move in over the road, money will then be found, and that until that happens no money will be found, but that is crystal ball gazing and no one can be sure. But I don't think they are going to have such a run down building in this area, but who knows they might. I just feel everytime a TV crew from abroad comes to film the Parliament they will inevitably choose to catch us in their shots!

*L: I'm also wondering in terms of the bigger picture - in terms of private funding in education and health etc?*

N: Well exactly, it's very much linked, you can see them putting in some public money and levering in more private money. This is just what they are doing with the new hospital at Little France. Whether it makes sense is very doubtful. But there is a consensus from all the mainstream political parties that that is the way to go, and the same with these transfers.

*L: Yes, but there is a difference between a Housing Association and a private landlord that is purely about profit?*

N: Well yes, you have a third way where there is a non-profit organisation, but there is no demand for that here. No one has ever said to me that the problem is that the Council is their landlord. And if they raise that, then I don't have any difficulty with that. If people were saying "let's change landlord", separately to the question: "let's live in decent modern houses," that would be another thing. It's the confusion of these two issues that I really object to. The fact that they are saying, if you want to live in proper houses you've got to vote to change landlord! There will obviously be all sorts of complaints about the Council, but basically people want certainty. I mean people living here have either been obliged or chosen not to buy houses. People are not looking to take gambles on the unknown, i.e. a Housing Association. They know the Council, they know they can vote for the Councillor or not, there is that accountability, and people just don't want something as fundamental as housing to rock the boat. The people that are the most scared now are the owner occupiers who are now on benefits and should never have bought. It really doesn't make sense to have the responsibility to repair, and get a bill to do these flats up, if you are on state

benefits. So, there are a lot of older owners here thinking where on earth am I going to borrow 'x' thousand pounds. Equally, people are worried about higher rents with Housing Associations, and they will only guarantee five years. Also my concerns are that mergers take place and the organisation you start dealing with, you might not be dealing with later on down the line. If the Housing Association doesn't deliver on its promises to refurbish the estates, that doesn't mean that the ballot is void and you go back to the Council, whereas if the Council tried to refurbish it and made a mess of it, you would at least have some comeback, you would imagine?

*L: So are you trying to get some of these securities and things addressed in the process?*

N: Oh, very definitely. I mean to my mind it's not even worth thinking of balloting on something, unless you have guarantees as to works proposed, i.e. the owners are signed up to it, so the tenants know what they are voting for, and crucially that our timescales are agreed, so you know whether it is in 2004 or 2008 when particular blocks are to be done up. You know, how people vote would very much depend upon that, that's why they will try and keep it vague.

*L: But ultimately, if I think this is the only way I will get my windows fixed, what can I do?*

N: But maybe it won't be the only way, maybe you say "okay we need to change landlord" and then you end up not getting them done anyway, because say 2 of the owners are refusing to spend any money (that they are not obliged to spend) and that means that the improvements in your particular block don't get done. So what I am saying is that very definitely we need certainty.

*L: Are the Council paying for the Association to provide residents with information and to participate in the consultation?*

N: The steering group members are all unpaid. If people had expenses, you know child care expenses and so on, they would, I am sure, be met by the Council, but it is certainly not paid. Essentially the Council would fund particular leaflet drops if we asked them to, but it would probably depend on what they thought our attitude to the process was. Certainly, if there were a ballot and if we did campaign actively against it then obviously we would be looking to other parties to fund us. I am quite sure they wouldn't pay to have their very expensive viewpoint worked against! You should ask people to show you some of the glossy literature they have produced, including the one introducing Edinvar and what a wonderful landlord they would be. This was just before they decided that the bid was unacceptable, and the process collapsed in January. Also the very early stuff is real propaganda. Although it is more veiled in the recent stuff, the thrust remains the same.

This interview was originally published as part of *The Dumb Record* art project, which is a project by Lyn Löwenstein, one of four artists who have been working with Dumbiedykes residents as part of *Scheming*, co-ordinated by the Collective Gallery in Edinburgh. More information, interviews and articles can



An Open Letter to glaspaper from Andrew Wishart from the Residents Group, Dumbiedykes housing estate, Holyrood, Edinburgh.

**to: info@glas-collective.com**  
**from: info@dumbyrecord.org.uk**

Dear Glas,

The Dumbiedykes Design Competition is an attempt to break out of the tangled mind-numbing mess that is Stock Transfer. We are done with discussing the outcomes of feasibility studies carried out by cautious consultants. Finished with discounting tenanted market values and projecting rental streams over the next thirty years at inflation plus 1%.

Down in Dumbiedykes we've spent the last four and a half years dealing with concepts like these, stuck in Stock Transfer Limbo while our houses and the environment deteriorates around us.

Down in Dumbiedykes the hard SIP (Social Inclusion Partnership) statistics show that:

- the houses have some of the worst energy efficiency ratings in Edinburgh
- 71% of households live on less than £150 a week
- male life expectancy is 59 years
- little of the new wealth generated by the Holyrood Project is spilling out across Holyrood Road.

Down in Dumbiedykes second best isn't good enough.

We would like to see a plan which addresses the design failures of the 1960's; which provides a sustainable community infrastructure and reconnects the estate with Holyrood and the Southside and most of all a plan which delivers decent, warm, affordable homes.

Two decades of under-investment and Right to Buy have left Council Housing in absolute crisis. The Dumbiedykes Design Competition seeks to widen the debate about investment in social housing and seeks solutions about how to break the cycle of poverty and injustice perpetuated in our run down schemes.

The Dumbiedykes Design Competition is open to all.  
 First Prize. One week in a Luxury Apartment in Dumbiedykes.  
 Second Prize. Two weeks in a Luxury Apartment in Dumbiedykes.

Yours truly,  
 Andrew Wishart

## Redesign Dumbiedykes! Open Competition

Proposals sought for the regeneration of the  
 Dumbiedykes Estate in Holyrood Ward, Edinburgh.

**The People of Dumbiedykes seek  
 architectural and investment models, which challenge the  
 status quo.**

### Introductory Brief

The Dumbiedykes estate has a unique inner city location close to the Scottish Parliament, and is an integral part of both the Holyrood Project and the Old Town redevelopment area. The estate consists of two distinct areas of high density housing, two blocks of high rise flats designed in the late 1950s and a large number of medium rise deck access tenement flats and maisonettes built in the mid 1960s. There are also 6 pensioner cottages. The present population of Dumbiedykes is approximately 1600 people.

The Holyrood area, which borders the estate, is the scene of much development activity and is one of the most exciting and dynamic parts of the city. The new Scottish Parliament building is under construction a

short distance away with new luxury residential, commercial and hotel premises either completed, or under construction. Land values in the area are reaching 1.5 million per acre and new housing properties are achieving values of up to £250,000. Dumbiedykes now lies in stark contrast to its surroundings, with the need for major investment in the physical fabric and environment, ever more apparent.

The Edinburgh Council has, in the last 5 years, been promoting a New Housing Partnership Stock Transfer proposal for the estate. The process appears to be unworkable. The local community has reached the point of exasperation and are urgently seeking radical and innovative ways to improve the physical and environmental aspect of the estate, to ensure that it does not become further

isolated and excluded from a rapidly developing area.

The community's primary aim in promoting this competition is to ensure that the best possible regeneration of the estate is achieved, and to maintain the distinct historical character of social housing in Dumbiedykes.

Dumbiedykes has to be seen as an integral part of 'Planet Holyrood' both physically and culturally! The people of Dumbiedykes propose this design competition in the hope that the ideas, discussion and designs generated by it, will lead to a realisation of the visionary potential of the estate.

The Competition is open to all and we are seeking both architectural and investment models, which challenge the status quo.

For more info email: info@dumbyrecord.org.uk  
 Or write to : Andrew Wishart, Design Competition, ITC Centre, Dumbiedykes Road, Edinburgh EH8 8AN

# EDUCATION, PROPAGANDA AND THE ORIGINS OF THE MODERN DOCUMENTARY

by Ray Lucas

Documentary film has played a central historical role in mass audiences understanding of contemporary issues. The medium has since its inception been subjected to charges of bias and has been used in openly propagandist ways. Considered one of the pioneers of the genre, Scots born John Grierson was responsible for many of the most famous early documentaries including *Night Train*. Here his political attitudes and social prejudices are discussed in relation to two of his most important films – *Housing Problems* and *Industrial Britain*.

John Grierson was born in 1898 in Deanston, spending much of his childhood in Cambusbarron and his university years in Glasgow; he spent much of his later life in Canada. He is widely regarded as the founding father of the documentary film. His early theories on the applications of film beyond the bounds of fiction and newsreel reportage have had a lasting effect upon both film theory and practice.

Grierson's political background places him at the fringes of the socialist and labour movements in Scotland. He was attending Glasgow university at the time of the Red Clydeside, and flirted with Communism at various points in his career. Grierson's belief was that film could be used as a tool of governments and other such institutions. He later became a firm believer in establishment politics, and sought to build film-production units within the government machine. This shows up the basic dichotomy in Grierson's political views. His personal views were distinctly radical and left-wing. His interest in the idea of the government film unit with its agenda of education and propaganda sometimes fell on the other side of the political divide.

In 1935, Grierson was head of the General Post Office (GPO) film unit, which he had established from the ruins of his earlier Empire Marketing Board film unit. He would later meet with real success at the National Film Board of Canada, which still successfully pursues a programme of government-funded filming today. Grierson also played an important role in bringing documentary to television through his shows *This Wonderful World* and *John Grierson Presents*; which ran well into the 1960s.

Before embarking upon his career as a film producer, Grierson spent time in Chicago, Hollywood and New York as part of a scholarship from the Rockefeller Foundation. The subject of his study was mass communications. Initially, his focus was on the ways in which information reached the immigrant populations in Chicago. His examinations of the 'Yellow Press' (popular

newspaper aimed at immigrant groups) gave Grierson the idea that sensationalism and entertainment were important tools for education and communication. The varied populations could follow stories in simple language with the aid of lurid details and banner headlines better than they could the broadsheet style of analysis and report. The dramatic narrative thread was important to imparting information. This did not sit well with the prevailing thought in the US at the time. Indeed, his study had been instigated in order to prove that the new immigrant populations could not be educated or informed, and that they should be disenfranchised from the democratic system.

Given his remit of studying public information, Grierson naturally turned to the fledgling film industry. He was hired by some of the biggest studios such as Famous-Players-Lasky; in order to help them with audience demographics. This was one of the first times that a study of this kind had been attempted, and Grierson had the opportunity to examine raw data collected by the studio which investigated how popular films were with different audiences. This information together with his examination of the popular press sparked some of Grierson's ideas for the documentary. The key idea was that factual information could be presented through the dramatic narrative; that a story should be told.

The two films which I will discuss here are both variations on Grierson's documentary theory. *Housing Problems* was produced by the GPO Film Unit in 1935 for the Gas Light and Coke company. The team for this included Ruby Grierson, John's sister, and Edgar Anstey. *Industrial Britain* was directed by Robert Flaherty for the Empire Marketing Board film unit in 1931. This film boasted the best film photography of the EMB period due to the experience and expertise of Flaherty. Basil Wright and Arthur Elton shot additional footage in order to complete the film, which was edited by Grierson and Anstey.

*Housing Problems* was a long held ambition of Grierson's, which he realised in 1935. Whilst writing film review for the New York Sun, Grierson came to review films by Robert Flaherty. It was in one of these reviews that Flaherty coined the term 'documentary'. Flaherty was famous for producing films such as *Nanook of the North* and *Moana*. These were romantic portraits of life in the exotic corners of the world. Grierson once challenged Flaherty to turn his poetry to the working classes of Northern England- and this film is the eventual result. Of course, the idea of the individual genius in the EMB left room for no-one else but Grierson. The team surrounding Flaherty was very important, consisting of Grierson's staff including Basil Wright and Edgar Anstey-

who eventually had to complete the film after Flaherty's technique of shooting reel upon reel of test footage almost bankrupted to EMB. The resourceful Grierson had no less than six other films made out of this extra test footage.

The romantic notion of the working classes in this film highlighted some of the problems with Grierson's documentarists appointing themselves as the voice of the working classes. They aestheticised the work process to such a degree that it was not recognisable. Grierson and his team at the EMB were sympathisers for the labour movement, but they all had upper middle class backgrounds and university education. A film such as *Industrial Britain* had the effect of reassuring the middle class audiences it was aimed at, that the working man was happy with his lot, and that all was well with the world.

The film includes sections in the Wedgewood potteries, Rolls Royce factory production and glass blowing. The aim was to show the skill and craftsmanship still employed in the industrial age. The film was produced by the Empire Marketing Board, and, unlike some earlier EMB productions, did not get an individual release in cinemas. Indeed, at this time, the documentary was having problems being shown at all, as sound film had recently been introduced. The film was shown widely, however. It was sent overseas, across the empire, as part of the EMB mission to share and advertise Empire produce. It was felt that there was a growing divide between knowledge of product and process- these films were designed to help the audience appreciate the effort represented by the goods they were purchasing.

The line between advertising and education is already a little blurred at this stage in the documentary. This was to become more pronounced when the EMB was taken over by the General Post Office. This body, also run by Grierson, was more willing to accept sponsorship from commercial concerns, such as the Gas Light and Coke company, who commissioned a series of films in the 1930s.

*Housing Problems* is a complex film on account of the way in which it was produced and commissioned. The project started as a commission from the Gas Light and Coke company, who wanted to promote their new gas fuel as an alternative to smog-producing coal. The film had at its disposal new sound recording equipment, which was just about portable. It was Grierson's policy to take advertising work such as this, and to allow his team to work in a more political angle where they could.

A key to the success of this film was the involvement of Grierson's sister, Ruby. An important film-maker in her own right, her life was cut short by a U-Boat attack on her crossing to Canada. It was her idea to take the microphone to the people living in the slums, to allow them to tell their own story in their own words. Ruby had commented to her brother, John Grierson that 'the trouble with you is that you look at things as though they were in a goldfish bowl... I'm going to break your goldfish bowl.'

In making *Housing Problems*, she said to the slum dwellers featured in the film: 'The camera is yours. The microphone is yours. Now tell the bastards exactly what it is like to live in the slums.'

The promotion of overly optimistic images

at the end of *Housing Problems* has led to comments by critics that the commercial nature of the commission had compromised the social and critical comment of the film. Grierson, of course, portrayed this situation differently, arguing that the critical material had been inserted into what would have been a largely positivist film, typically turning the criticism on its head.

This film is reported to have had an enormous impact upon the audiences of the time, as it was the first time problems such as those of the slums were presented in such a convincing way. Its use of pseudo-investigative journalism, and the bravery of taking the camera and microphone into the slums to record what people had to say were genuinely novel ideas.

The film represents a rallying call for the conscience of the documentary film movement, as it shows both the best and the worst of the genre. The best being represented by the way in which people were able to speak out for themselves from the most deprived circumstances; but also to exploit this in the service of commercial interest- to use their voice to sell a product was a betrayal of their interests.

These two films illustrate some of the different approaches to the documentary, and throw up some of the problems inherent in some of its approaches. Grierson himself was well aware of the problems of realism; and presented his own variation on this. He refers to his films as actuality pieces, rather than being in pursuit of realism. This is an important qualification of his work. His aim was to dramatise and narrate real issues and ideas. We see in these films two representations of space- the space of work and the space of the slums in the inter-war years.

How does all of this relate to architecture? In the most immediate way, we have two patterns of how the professional classes condescend to and reassured themselves about the working classes. The presentation of life in *Industrial Britain* is of the 'noble working man' who lives that simple life of toil, and has quality and worth imparted to him through this usefulness. The presentation in *Housing Problems* is troublesome in other ways; for despite the intention in some instances of giving the impoverished their own voice in cinema, the film is compromised by commercial interest and this voice is used to validate and endorse an advertisement for gas.

We also have two representations of space. The working and living space of the British working class in the 1930s. These two representations had the same original intention: education, and the same political sympathies behind them. The two representations differ in radical ways, and give a view of life that is far from Grierson's actuality; being as they are, coloured by different interests: those of art, poetry and aesthetics; and those of commercial interest and reconstruction propagandist.

*Housing Problems* and other films by the EMB and GPO film units are available on the BFI video Britain in the Thirties.







# EVEN HOTTER DEALS



## OUR LOWEST PRICE PROFESSOR ALL-IN-ONE



### PROFESSOR All-in-One Lecturer, Tutor, and Manager

more than ten years of training in client / customer relationship - excellent at dealing with legal issues, 'pass' guaranteed courses, PROFESSOR uses more and more common methods of quantitative assessments!, UNI WORLD regularly monitors work of PROFESSOR in order to secure highest ratings possible, top scores in securing funding for research projects through long established alliances with companies and government, **MONEY BACK if not entirely satisfied after completion of degree!**

MODEL: BAS 341 736 712  
Code: 5+  
Was £17,998 for 4 years

**SAVE**  
**£4,499.50**

**UNI WORLD PRICE**  
**£17,998** EXC. VAT  
**FOR 5 YEARS\***

\* Buy 5 years tuition for the price of 4. Conditions apply. CLIENT must not pursue any legal actions against PROFESSOR or UNI WORLD for the duration of the course nor thereafter.

**Unbeatable Low Prices**

At UNI WORLD we are always STAMPING DOWN ON PRICES and offer our customers unbeatable prices. We will give you 110% of the difference back if you can find a lower price for the same product and offer from another store.\*

**TRADE-IN**  
your old degree  
for new one  
and get a second  
one for 50% off  
the regular price.

Shop on-line at  
**uni-world.co.uk**

Or order direct from Uni World on  
our credit / debit card order line on 0141 4296891

**WEB ONLY OFFER**

This offer is only available from 1 October 2002  
Not all degrees available. Check for a complete list of degrees. All available degrees come with certified papers. Prices vary!  
**HURRY! WHILE STOCK LAST**

## APPLY NOW ONLY A FEW PLACES LEFT...

UNIVERSITY OF THE CONSTRUCTION INDUSTRY

**Bpfim**

BACHELOR OF PFI (Private Finance Initiative)  
in Advanced Management Studies

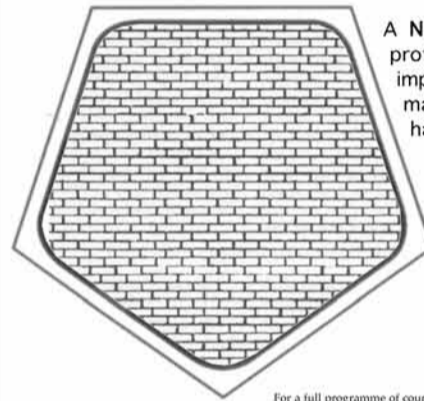

A NEW management school started by working professionals who passionately believe in the importance of teaching only the technical art of making buildings. Comprehensive, intensive and hands-on training in various subjects.

Short courses & seminars in:  
BUILDINGS, SCHEDULING & BUDGETING  
LAW, CONTRACT, DISTRIBUTION  
PRODUCTION, ACCOUNTING & TAX  
FREELANCING, INSURANCE and many more...

For a full programme of courses and seminars and our extensive range of Bachelor and Masters programmes in PFI call +44 141 2396891

Get the best new books on **Motivational Studies** in paperback without having to wait!

Massive discounts + a University-Starter-Pack when you join now!

5 books for only **£5**  
**FREE p&p**

[www.join-motivationalstudies.co.uk](http://www.join-motivationalstudies.co.uk)

The International School of Teaching

**Fast-track courses in all relevant subjects regarding part and full-time teaching jobs. Most courses completed within 6 weeks and include free police certificate.**

contact ITS, London, personell office

# UNI WORLD

The University Superstore

\*We will do this where the offer is available to purchase from stock to another retail store - either before your purchase, or within 7 days of your purchase from UNI World. You will need to produce your receipt where you have already purchased. We will not do this for the opening, closing down, ex-display, clearance, special order, members only or extended warranty prices. ©GDS Retail Limited, Oakfield Avenue, Brimstead, BS3 9TP. Credit / Debit cards only. Cheques can only be accepted in store. Cancellation period normally applies. All offers subject to availability. Ask in-store for details.

# Small Ads

## learning tools

**WHO WANTS TO BE A SCHOOL TEACHER?** Based on the popular TV quiz show, this home study board game will help you work towards the necessary qualifications to take up a job in education. The salary might be rubbish, and the status low but the studying can be shared with

**BACK TO SKOOL**  
**Hard Hats, overalls and dust masks all at ridiculously low prices. Don't take a chance that your PFI school will have been finished on time or to a satisfactory standard.**  
 (ref 74001)

all the family (ref. 476)  
**PHILOSOPHON** Hundreds of Audio tape kits to choose from. Wittgenstein, Plato, Smith, Hobbs, Aristotle. Contemplate the Meaning of Life while you sleep with these user friendly tapes based on University Lectures now deemed surplus to requirements

## education services

(ref. 539)  
**HOW TO GUIDES** Numerous easy to use guides for planners and architects. The best selling How To Satisfy Community Participation Criteria has been updated and expanded to include Stock Transfer schemes. Could make a real difference to your companies balance sheet (ref. 3992)  
**BLACK MARKET PROFESSORS FOR HIRE** recently arrived University Professors from Palestine,

Afghanistan and countless other countries which the Foreign Office doesn't approve of and prevents from working whilst waiting for asylum. Fancy tuition in Nuclear Physics, Linguistics or Nuro Surgery? Then why not drop into your local Immigration Office and ask for details. (ref. 3548)

**ACADEMICS ANONYMOUS** talk openly with other demotivated, misunderstood university academics. Don't take it out on your students when there are others who can help. (ref. 553908)

**SIGN UP FOR THE NEW NATIONAL INTELLIGENCE LEAGUE TABLE** to secure your rightful place in the knowledge led economy. Similar to DNA databases, the NILT will log your IQ and place you in relation to your fellow citizens. No longer will you have to question your workmates intelligence. Simply check the facts out with NILT. (www.nilt.gov.uk)

**EDUCATION LOTTERY SCHEME** aimed at giving inner-city working class children the opportunity to win weekends away at exclusive, fee paying schools in the country. (see local press for details)

**DESIGN YOUR OWN DEGREE CERTIFICATE** Make your meaningless qualification stand out from the rest. Add colour to your grey degree and impress future employers (ref. 29194)

**I'M A NOBEL PRIZEWINNER GET ME OUT OF HERE** Stuck in an underfunded British University trying to conduct ground breaking research? Why not apply today for the upcoming reality TV show - "I'm a Celebrity, get me out of Here!" (ref: 44914)

**HOW TO BLUFF YOUR WAY IN ENGLISH** This and countless other pocket books can make all the difference when trying string a sentence together or construct a

legible argument (ref. 55025)  
**DO-IT-YOURSELF DEMOCRACY** disillusioned by the 'no-choice' Stock Transfer referendum in your area? Try our DIY pack today and learn about the advantages to be had from offering voters more than one choice (ref. 45901)

**NIGHT CLASSES IN DIRECT GOVERNMENT** Try one of our tailor made courses aimed at communities repeatedly ignored by their local governments. After a couple of sessions you will be

## courses

able to take control of your own affairs through direct democracy and avoid those unnecessary cuts and closures (ref. 90882)

**FAST TRACK ARCHITECTURE COURSES** Learn about revolutionary computer software and commercial skills which will enable you to bypass design, consultation and will avoid any discussion of social responsibility. (ref. 54398)

**NEW DEAL INSTRUCTORS WANTED** Must be able to patronise and disillusion out of work poets, painters, philosophers, daydreamers with banal lessons in letter writing and 'shaving for interview' (ref. 516)

## positions vacant

**GEORGE WIMPEY PROFESSORSHIP IN URBAN PLANNING** Suitable candidates sought for this prestigious post. Must promote the virtues of low density suburban design models. No Dutch need apply. (ref. 29987)

**LAND FOR SALE** School playing pitches available for sale. Would suit Volume Housebuilder and Land Speculator. Play your part in the rise in child obesity (ref. 49224)

**ALMOST NEW TEXTBOOKS** Badly

## misc.

out of fashion Marxist textbooks. Would swap for 'Friends' videos or Victoria Beckham Biography. (ref. 29110)

**CORPORAL PUNISHMENT SUMMER SCHOOLS** Are your children

## books

getting away with murder in 'violence-free state schools? Put their names down today for the Thrashfest Summer School to be held this summer on the Isle of Man (call now 0888 453453)  
**CLASS SIZE CUTTER** suits all age groups. The revolutionary class size cutter ensures that 20% of any given classroom is deemed uninhabitable due to dampness, draught, overheating or sun glare. Call your Education Authority today. (ref. 31890)

## BOOKS, BOOKS, BOOKS, ....

**Recently closed Public Libraries offer you the chance to pick up thousands of valuable books for next to nothing. Read them, burn them, its your choice. Create your very own library at home to make up for the loss of your community based facility which has catered for generations of readers. Contact the Director of Education at your local authority for more details.**

## BOOKS, BOOKS, BOOKS, ....

EDUCATION, EDUCATION,

## WISDOM FOR BEGINNERS vol. 1 - 12

This timeless classic is a bookshelf or coffeetable must for all discerning gentlemen and ladies seeking the allure of genuine wisdom. Catch the eye of attractive strangers and the respect of dinner party guests with WISDOM FOR BEGINNERS exhaustive range of witticisms and words of advice.



"Never mix business with pleasure or your eggs will never hatch"  
 take it from me says one of many fully satisfied readers of  
 WISDOM FOR BEGINNERS

INTRODUCTORY OFFER PRICE  
**£19.95**

**EDUCATION AND OTHER HITS** This easy-listening double CD of Tony Blairs speeches captures the best of bubble gum populism. In the car, the garden or with the family, no matter how often you listen you'll be whisked away to a fantasy land (ltd stock) (ref. 439)

**CHAIRS FOR SCHOOLS** Following the success of the governments 'Computers for Schools' programme, this new initiative offers the private sector tax breaks in return for old or broken furniture (ref. 33098)

**ADVERTISE IN GLASPAPER ARTICLES FOR SALE AND WANTED glaspaper 0141 4296891**

Advertisement

# Is Your Memory Like a Sieve?



Forget names, faces?



**WORLD FAMOUS MEMORY** experts, who have trained quiz show contestants, political leaders and priests have written this exclusive book which not only promises to improve your ability to retain knowledge, but gaurantees to improve your quality of life. Never again need you experience those awkward moments when you meet someone you'd rather have forgotten and suddenly discover that you have!

'Complete Memory for All!' has been an international bestseller in over 50 countries. This is your opportunity to purchase it at the special price of \$45.95!

Don't waste your time with second rate immitations! You are allowed to FORGET about them!

What are you waiting for - start improving your memory today and see the difference !!

# Why Does Your Memory Fail You At All The Wrong Moments?

## WHAT THIS BOOK CAN SHOW YOU

- How to remember names, faces, facts and figures!**
- How to earn more - get a better job!**
- How to learn faster!**
- How to increase your personal efficiency!**
- How to speak fluently without notes!**
- How to recall facts without the slightest idea of what they might mean!**
- How to impress your friends!**
- How to bluff your way in the classics!**
- How to achieve lasting happiness!**

***War is not a contradiction of capitalism***



***but its final means of accumulation***